



Electronics International Inc.

CGR-30P

Installation Instructions

II 02151301 - Rev. E: 5/8/15*****

The CGR-30P is an FAA-Approved Primary Replacement
for Engine and Aircraft System Instruments

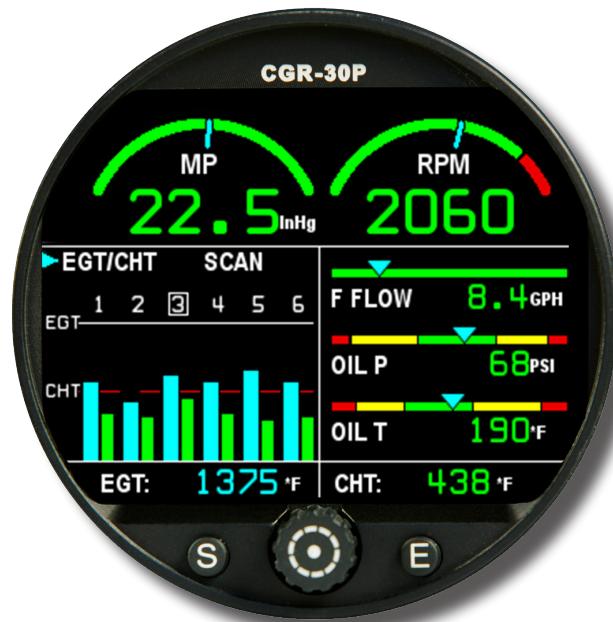

Read this manual before installing this instrument. It contains information that may affect your decision to install this product and/or the safety of your aircraft.

Model # : _____

Serial # : _____



63296 Powell Butte Hwy • Bend, OR 97701 • (541) 318-6060 • iFlyEi.com

Important Notice

***** MUST READ *****

If you think it is not important to read this manual, you're wrong! This manual contains important operating information that may affect the safety of the pilot, passengers, aircraft, operation of the system or time to install the system. You **MUST** read the manual prior to installing this system. Any deviation from these installation instructions is the sole responsibility of the installer and should be done in accordance with AC 43.13.

Read the Warranty/Agreement. There is information in the Warranty/Agreement that may alter your decision to install this product. **If you do not accept the terms of the Warranty/Agreement, do not install this product.** This product may be returned for a refund. Contact Electronics International Inc. for details.

If you are not an FAA Certified Aircraft Mechanic familiar with the issues of installing aircraft EGT, CHT, RPM, M.P., Fuel Level, Fuel Flow, Fuel Pressure, Volt, Amp, Oil Temperature and Pressure instruments, Do Not attempt to install this instrument. The installer should use current aircraft standards and practices to install this system (refer to AC 43.13).

If the installer does not have the skills, knowledge, tools, equipment or facility, to perform and determine whether the installation of this product is safe, reliable and accurate and to determine whether this product is operating properly after installation, **DO NOT INSTALL THIS PRODUCT.** If the owner/pilot and/or installer are unwilling to take the responsibility for the installation and operation of this product, **DO NOT INSTALL THIS PRODUCT.** This product may be returned for a refund. Contact Electronics International Inc. for details.

By installing this product, the aircraft owner/pilot and installer agree to hold Electronics International Inc. harmless and in no way responsible for monetary compensation, including punitive damages for any incident, harm and/or damage associated with this product. If you do not agree to the above, **DO NOT INSTALL THIS PRODUCT.** This product may be returned for a refund. Contact Electronics International Inc. for details.

Electronics International Inc. is not liable or responsible for a pilot's action or any situation that results in personal injury, property damage, missed commitments, lack of use of an aircraft or any expenses incurred due to: product failure, inaccuracy in displayed data or text files, display or display format issues, software bugs or problems, upgrade or customization issues, misinterpretation of the display, warning and/or limit settings, calibration problems, installation issues (leaks, mis-wiring, obstructions, damage to aircraft or components, incorrect installation of any parts, wrong parts, parts that don't fit, etc.) or any other issues related to the installation or operation of this product. All of the above are solely the pilot's and/or installer's responsibility. The pilot **must** understand the operation of this product before flying the aircraft. The pilot must not allow anyone to operate the aircraft that does not know the operation of this product. The pilot must keep the instrument Operating Instructions in the aircraft at all times. If you do not agree to the above, **DO NOT INSTALL THIS PRODUCT.** This product may be returned for a refund. Contact Electronics International Inc. for details.

Do not install a non-certified CGR-30P (CGR) in a certified aircraft. A certified CGR lists the applicable TSO numbers at the bottom of the Model Label.

Before starting the installation make sure the unit will fit in the location you intend to install it without obstructing the operation of any controls.

Important Notice

***** MUST READ *****

If the CGR is configured to monitor the aircraft's fuel tanks, the CGR must be calibrated to the aircraft fuel system and the CGR's accuracy must be verified before flying the aircraft.

The accuracy and proper operation of each function displayed on the CGR should be verified before the aircraft is released for flight.

When the installation is finished, inspect the system for loose fittings, connections, clamps, probes and inspect for leaks, chafing, obstructions, heat damage and anything that may cause unsafe flight before the 1st run-up, after the 1st run-up and after the first flight.

Before allowing the aircraft to be flown, verify the instrument markings displayed on the CGR screens are accurate with the aircraft's POH for every function displayed on the CGR.

Before allowing anyone to operate the aircraft they must read the Operating Manual including the Important Notice therein. Keep the Operating Instructions in the aircraft at all times.

The use of the CGR requires recurring training for any pilot who will be flying the aircraft in which it is installed. Recurring training should include reading the CGR Installation Manual and Operations Manual and seeking a flight instructor for proper interpretation of information being displayed to the pilot.

Fuel Level Accuracy Limitations:

The accuracy limitations of the CGR are listed below. **It is the pilot/owner's obligation to make anyone flying the aircraft aware of these limitations.**

- 1. Angle of Attack** - The CGR must be calibrated with the aircraft in a cruise angle of attack. If the aircraft is in an angle of attack other than cruise, the CGR may display inaccurate fuel levels (depending on the mounting location and type of sensor used). If your aircraft does not sit at a cruise angle of attack when on the ground, it may not display accurate fuel levels. **Test your aircraft at different angles of attack to see the affects on the CGR fuel level readings.**
- 2. Full Fuel Readings** - As a tank is filled the fuel sensor may not be able to detect the fuel entering the upper corners of the fuel tank. If this is the case with your sensor, the CGR will display lower fuel levels than the actual fuel in the tanks when the tanks are full. When the fuel level drops to a point where the fuel sensor starts to detect a change, the displayed fuel level should be accurate. **Check the accuracy of your system by comparing the displayed fuel levels on the CGR to the fuel levels listed in the flight manual at each fill up.**
- 3. Low Fuel Readings** - **Do not rely on the CGR to determine the fuel level in the tank for an indicated tank level below 1/8.** You should always fly the aircraft in such a manner as to maintain at least the FAA minimum fuel requirements in the aircraft at all times.

Important Notice

******* MUST READ *******

4. Improper Calibration - If the CGR has not been properly calibrated it will not display accurate fuel levels in the tanks. It is important you verify the accuracy of the CGR. **Always crosscheck your measured fuel levels in the tanks with the readings on the CGR before each flight.**

5. Poor Connections - Poor connections between the wires leading from the EDC to the fuel sensors can become intermittent. An intermittent connection most likely will show up as wandering or inaccurate readings on the CGR. **Always crosscheck your measured fuel levels in the tanks with the readings on the CGR before each flight.**

6. Defective Fuel Level Sensors - Fuel sensors can become intermittent or change resistance with age. It is not uncommon to find intermittent problems even in new sensors. An intermittent problem with a fuel sensor most likely will show up as wandering or inaccurate readings on the CGR. **Always crosscheck the measured fuel levels in the tanks with the readings on the CGR at each fill up.**

If you ever find an inaccuracy issue or any other problem with a fuel level display on the CGR, troubleshoot and fix the problem before flying the aircraft.

If you do not agree to all of the above, **DO NOT INSTALL THIS PRODUCT.** This product may be returned for a refund. Contact Electronics International Inc. for details.

Important Fuel Level Considerations:

DO NOT RELY SOLELY ON THE FUEL LEVEL DISPLAYED ON THE CGR TO DETERMINE THE FUEL LEVELS IN THE AIRCRAFT. The use of the CGR does not eliminate or reduce the necessity for the pilot to use good flight planning, preflight and in-flight techniques for managing fuel. It is important the pilot adopt the practices listed below. If you are not familiar with these techniques, contact the FAA to acquire proper training.

- 1. A copy of the Operating Manual must be in the aircraft at all times.**
- 2. Flight Planning** - Always calculate the fuel requirement for each leg of a flight, including any alternate plans for bad weather. Keep this information available in the aircraft during the flight. Keep a chart of the published fuel flows for various flight/engine conditions in the aircraft. Keep a chart of the measured fuel flows for various flights in the aircraft. Measured fuel flows can be considerably different from published figures. This usually is due to old, inaccurate engine instruments.

Important Notice

******* MUST READ *******

- 3. Preflight - Do not rely on the CGR to determine the fuel level in the fuel tanks. The pilot must visually check/measure the fuel levels in the tanks before every takeoff.** Crosscheck the measured fuel levels with the displayed levels on the CGR. Also, crosscheck these levels with the fuel requirements for the flight listed in your flight plan.
- 4. In Flight - Make the CGR part of your normal instrument scan. Crosscheck the fuel levels displayed on the CGR with your flight plan at each leg of the flight or every 30 minutes (whichever happens first).** If there is a discrepancy, land the aircraft at the nearest airport and verify the fuel levels. **Discrepancies should be taken seriously.**
- 5. New Pilot or Owner of the Aircraft - If there is a new pilot or owner of the aircraft, it is the previous aircraft pilot's/owner's responsibility to insure the new pilot has read this manual and is aware of any accuracy limitations and other important considerations. All limitations and operating characteristics learned from operating the CGR must be passed on to the new pilot/owner.**

If you do not agree or are unwilling to comply with the information/requirements contained within this Important Notice, **DO NOT INSTALL THIS PRODUCT.** This product may be returned for a refund. Contact Electronics International Inc. for details.

Contents

Warranty/Agreement-----	1
1.0 System Description -----	3
1.1 System Description -----	5
1.1.1 CGR Display -----	5
1.1.2 EDC-33P -----	5
1.1.3 Probes, Transducers and Modules -----	5
1.1.4 Wiring & Extension Cables -----	5
1.2 Operational Overview -----	6
1.3 Installation Overview -----	6
2.0 Hardware Installation -----	7
2.1 Important Information and Initial Check Out: -----	9
2.2 Review the "EDC Wiring Work Sheets:" -----	10
2.3 Verify you have all the necessary Probes, Modules, Transducers and Cables: -----	10
2.4 Install the CGR Display: -----	10
2.5 Install the Temperature Probes: -----	11
2.6 Install the Pressure Transducers: -----	13
2.7 Install the CO Detector, G-Sensor and/or Other Available CGR Options -----	16
2.8 Install the Shunt: -----	16
2.9 Install the Fuel Flow Transducer: -----	18
2.10 Install the P-300C Fuel Level Probes (OEM or Experimental) -----	25
2.11 Install the P-300M Fuel Level Sender: -----	25
2.12 Install the Resistive Fuel Level Module (RFLM-4-X): -----	26
2.13 Install the Intensity Control Pot CP-1A (optional): -----	26
2.14 Install the Master Warning (red) and Caution (yellow) Lights: -----	27
2.15 Install the Interface Circuit for a PWM Backlight System (Optional): -----	27
2.16 Install the USB-6A (Optional): -----	28
2.17 Install the FM-SC or AC-1 Converter (Optional): -----	28
2.18 Install any Additional Modules (Optional): -----	28
2.19 Install the EDC-33P: -----	28
3.0 Install the EDC Wire Harnesses and Route Wires -----	29
3.1 Attach the three EDC 37-pin wire harnesses to the EDC: -----	31
3.2 Connect the EDC Harness to the Temperature Probes: -----	31
3.3 Connect the EDC Harness to the Pressure Transducers: -----	31
3.4 Connect the EDC Harness to the Shunt: -----	31
3.5 Connect the EDC Harness to the Fuel Flow Transducer: -----	32
3.6 Connect the EDC Harness to the Existing Capacitive Fuel Level System: -----	32
3.7 Connect the RFLM-4-x Harness to the EDC Connector and to the Resistive Fuel Level Sensors: -----	33
3.8 Connect the EDC Harness to the EI P-300C Capacitive Fuel Level Probes: -----	33
3.9 Connect the EDC Harness to the P-300M Magnetic Fuel Level Senders: -----	34

Contents

3.10 Connect the EDC Harness (Volts Measurement Pin) to the Bus: -----	34
3.11 Connect the EDC Harness to the RPM Signals: -----	34
3.12 Setup the EDC for a 4 or 6-Cylinder Engine: -----	34
3.13 Connect the EDC Harness to Power and Ground: -----	35
3.14 Route the EDC 5V-Serial Wire to the CGR Connector: -----	35
4.0 Install the CGR Wire Harness and Route the Wires -----	37
4.1 Attach the CGR 25-pin D-sub Connector to the CGR: -----	39
4.2 Connect the EDC 5V-Serial Output Wire to the CGR 5V-Serial Input Wire: -----	39
4.3 Connect the CGR Harness to the Master Warning and Caution Lights: -----	39
4.4 Connect the CGR Harness to the Moving Map Data Out from the GPS: -----	39
4.5 Connect the CGR Harness to the Fuel Data Input on the GPS: -----	39
4.6 Connect the CGR Harness to Power and Ground: -----	40
4.7 Connect the CGR Harness to the CO-Guardian CO Detector: -----	40
5.0 Mandatory System Setup and Checkout -----	41
5.1 Power-On Checkout -----	43
5.2 Perform all Steps Listed in the "CGR-30P Setup Checklist" -----	43
5.3 Ground Run Checkout -----	43
5.4 First Flight Checkout -----	44
5.5 Read the "Warranty/Agreement" and the "Important Notice" -----	44
6.0 Installation Data -----	45
6.1 Instructions for Continued Airworthiness (ICA): -----	47
6.2 Airworthiness Limitations: -----	47
6.3 Installing a D-sub Pin onto a TC or Tin Copper Wire: -----	47
CGR-30P Wiring Work Sheet -----	49
EDC Wiring Work Sheet Top Connector -----	50
EDC Wiring Work Sheet Middle Connector -----	51
EDC Wiring Work Sheet Bottom Connector -----	52
EDC Template -----	53
7.0 Troubleshooting -----	55
7.1 CGR or EDC Problem -----	57
7.2 Pressure Problem with one Function -----	58
7.3 Temperature Problem on all Channels -----	58
7.4 Temperature Problem with one Function -----	59
7.5 RPM Problem -----	59
7.6 Fuel Flow Problem -----	60
7.7 Amp Problem -----	61
7.8 Resistive Fuel Level Problem -----	61
7.9 Capacitive Fuel Level Problem -----	62
7.10 Voltage Problem -----	63

Contents

8.0 Technical Data -----	65
Specifications, Functions and Features -----	67
Appendix -----	A-1
A1.0 Appendix: LASAR Ignition RPM Filter -----	A-3
A2.0 Appendix EDC-33P-8 for 7, 8, 9-Cylinder Engines and High RPM Engines -----	A-4
A3.0 Appendix Connecting an EDC RPM Channel to a Lightspeed Plasma II or III Ignition -----	A-5
A4.0 CGR-30P Twin Engine Installation Instructions -----	A-6
STC and AML -----	LastPages

Warranty / Agreement

Electronics International Inc. (EI) warrants this instrument and system components to be free from defects in materials and workmanship for a period of one year from the user invoice date. EI will repair or replace any item under the terms of this Warranty provided the item is returned to the factory prepaid.

1. **If you do not agree to and accept ALL the terms of this Warranty/Agreement, DO NOT Install This Product.** You may return the product for a refund. Contact Electronics International Inc. for details.

2. Electronics International Inc. is not liable or responsible for a pilot's action or any situation that results in personal injury, property damage, missed commitments, lack of use of an aircraft or any expenses incurred due to: product failure, inaccuracy in displayed data or text files, display or display format issues, software bugs or problems, upgrade or customization issues, misinterpretation of the display, warning and/or limit settings, calibration problems, installation issues (leaks, mis-wiring, obstructions, damage to aircraft or components, incorrect installation of any parts, wrong parts, part that don't fit, etc.) or any other issues related to the installation or operation of this product. All of the above are solely the pilot's and/or installer's responsibility. The pilot **must** understand the operation of this product before flying the aircraft. The pilot will not allow anyone to operate the aircraft that does not know the operation of this product. The pilot will keep the instrument's Operating Instructions in the aircraft at all times.

By installing this product, the aircraft owner/pilot and installer agree to hold Electronics International Inc. harmless and in no way responsible for monetary compensation, including punitive damages for any incident, harm and/or damage associated with this product (including but not limited to the ones listed above). If you do not agree to any part of this Warranty/Agreement, **DO NOT INSTALL THIS PRODUCT**.

3. This Warranty/Agreement shall not apply to any product that has been repaired or altered by any person other than Electronics International Inc., or that has been subjected to misuse, accident, incorrect wiring, negligence, improper or unprofessional assembly or improper installation by any person. **This warranty does not cover any reimbursement for any person's time for installation, removal, assembly or repair.** Electronics International retains the right to solely determine the reason or cause for warranty repair.

4. This warranty does not extend to any machine, vehicle, boat, aircraft or any other device to which the Electronics International Inc. product may be connected, attached, interconnected or used in conjunction with in any way.

5. Personal injury or property damage due to misinterpretation or lack of understanding of this product is solely the pilot's responsibility. The pilot **must** understand all aspects of the operation of this product before flying the aircraft. If he/she does not, he or she agrees to seek training from a knowledgeable instructor. The pilot also agrees that no one will be allowed to operate the aircraft who does not know the operation of this product and will **Keep the Operating Instructions in the aircraft at all times.**

6. The obligation assumed by Electronics International Inc. under this warranty is limited to repair, replacement or refund of the product, at the sole discretion of Electronics International Inc.

7. Electronics International Inc. is not liable for expenses incurred by the customer or installer due to factory updates, modifications, improvements, changes, or any other alterations to the product that may affect the form, fit, function or operation of the product.

8. Electronics International is not responsible for shipping charges or damages incurred under this Warranty.

9. No representative is authorized to assume any other liability for Electronics International Inc. in connection with the sale of Electronics International Inc. products.

10. You must read the entire Installation and Operating Instructions for this instrument. If you do not agree to and accept the terms of this Warranty/Agreement and the responsibilities set forth in these manuals, DO NOT install this product. Contact E.I. for a refund.

This Warranty is made only to the original user. **THIS WARRANTY IS IN LIEU OF ALL OTHER WARRANTIES OR OBLIGATIONS: EXPRESS OR IMPLIED. MANUFACTURER EXPRESSLY DISCLAIMS ALL IMPLIED WARRANTIES OF MERCHANTABILITY OR FITNESS FOR A PARTICULAR PURPOSE. PURCHASER AGREES THAT IN NO EVENT SHALL MANUFACTURER BE LIABLE FOR SPECIAL, INCIDENTAL OR CONSEQUENTIAL DAMAGES, INCLUDING LOST PROFITS OR LOSS OF USE OR OTHER ECONOMIC LOSS. EXCEPT AS EXPRESSLY PROVIDED HEREIN, MANUFACTURER DISCLAIMS ALL OTHER LIABILITY TO PURCHASER OR ANY OTHER PERSON IN CONNECTION WITH THE USE OR PERFORMANCE OF MANUFACTURER'S PRODUCTS, INCLUDING SPECIFICALLY LIABILITY IN TORT.**

System Overview

1.1 System Description

1.1.1 CGR Display:

1.1.2 EDC-33P:

1.1.3 Probes, Transducers and Modules:

1.1.4 Wiring & Extension Cables:

1.2 Operational Overview:

1.3 Installation Overview:

1.1 System Description:

The CGR-30P Glass Panel Engine Monitor installation consists of four major components: the CGR Display, the Engine Data Converter (EDC-33P), the Probes, Transducers & Modules, and the Wiring and Extension Cables.

1.1.1 CGR Display:

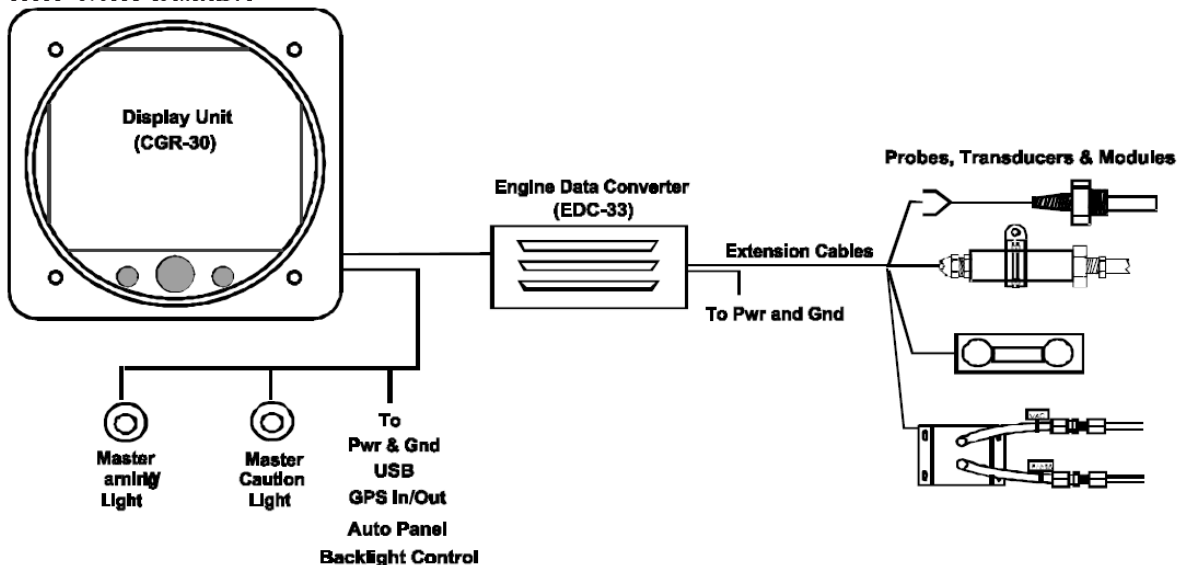

The CGR-30P (CGR) display measures 3.25" wide by 3.25" high by 4.36" deep and is designed to be mounted from behind the aircraft instrument panel.

The 25-pin D-sub connector on the back of the CGR display is used to interface the CGR to the EDC-33P, Power & Ground, GPS, Master Warning and Caution Lights and Audio Panel (experimental only).

1.1.2 EDC-33P:

The EDC-33P (Engine Data Converter, "EDC") converts all of the engine and aircraft system signals into serial data. This data is transmitted to the CGR display via one wire 5V-Serial Bus. Up to two EDCs can be connected to the CGR display. The EDC measures 4.5" long by 3.5" wide by 2.2" high and is to be mounted on the cockpit side of the firewall or in an equipment bay. The EDC reduces the wire bundle to the instrument panel by over 100 wires. There are three 37-pin D-sub connectors that interface the EDC to the various probes, transducers and modules.

1.1.3 Probes, Transducers and Modules:

The various probes, transducers and modules are mounted in the aircraft at appropriate locations.

1.1.4 Wiring & Extension Cables:

The extension cables and wiring provide the connections from the probes, modules or direct connections to the EDC inputs. Once the Wiring and Extension Cables are installed into the aircraft they become semi-permanent. Everything else (CGR, EDC, Probes and Modules) can be easily disconnected and removed.

1.2 Operational Overview:

The CGR system measures a primary engine or aircraft function using a probe or transducer and displays that function on the CGR screen using the following steps:

- A. A probe is mechanically connected to the aircraft and electrically connected to an EDC input. The pre-wired harness provides most of the electrical connections from the probes to the EDC inputs.
- B. The EDC converts the signals from the probes to a digital format and sends the data to the CGR through the serial bus. The EDC has 33 inputs. Many of these inputs can be used to monitor various types of functions.
- C. The CGR receives the data from the EDC and the data is processed through the CGR as follows:
 1. A Function is created in the CGR and is linked to an EDC input.
 2. The function is assigned a screen location onto the Main or System Screen of the CGR.
 3. Calibration, units, redlines, limits etc. are assigned to the data coming into that function.

Much of the setup for the certified CGR is done at the factory and cannot be changed by the pilot or installer. See the following Password Protection Section for more information.

1.3 Installation Overview:

The installer may want to use the “CGR-30P Installation Checklist” to install this system. The Checklist is a separate document provided with the CGR-30P system. The installer should start the installation by reviewing the CGR and EDC Wiring Work Sheets. There are four work sheets, one for each of the 37-pin D-Sub connectors on the EDC and one for the CGR. The work sheets are packaged with each of the three EDC wire harnesses and one for the CGR. The work sheets provide a list of the functions and probes/transducers included with this kit. For a twin engine installation refer to appendix A4.0. The installation is achieved by performing the following steps:

- A. The CGR display is installed. The CGR is mounted from behind the instrument panel in a standard 3 1/8" hole.
- B. Probes and Transducers are installed.
- C. Control Panels, Pots and Warning Lights are installed.
- D. The EDC is installed. The EDC should be installed on the inside of the cockpit or in an instrument bay with the connectors pointing down. For a twin-engine aircraft it can be installed on the backside (not the engine side) of the firewall with the connectors pointing down.
- E. The Wire Harnesses are installed. The wire harnesses for the EDC and CGR are pre-wired and included in the kit.
- F. Field Calibration/Setup steps are performed. If Fuel Tanks are to be monitored, the MVP-50 must be calibrated to the tank senders.
- G. System Checkout is performed.

Hardware Installation

- 2.1 Important Information and Initial Checkout:**
- 2.2 Review the "EDC Wiring Work Sheets:"**
- 2.3 Verify You Have all the Probes, Modules, Transducers and Cables:**
- 2.4 Install the CGR Display:**
- 2.5 Install the Temperature Probes:**
- 2.6 Install the Pressure Transducers:**
- 2.7 Install the CO Detector, G-Sensor and/or Other Available CGR Options:**
- 2.8 Install the Shunt (for Amps):**
- 2.9 Install the Fuel Flow Transducer:**
- 2.10 Install the EI P-300C Fuel Level Probes (OEM or Experimental Only):**
- 2.11 Install the EI P-300M Fuel Level Sender:**
- 2.12 Install the Resistive Fuel Level Module (RFLM-4-X):**
- 2.13 Install the Intensity Control Pot CP-1A (Optional):**
- 2.14 Install the Master Warning (red) and Caution (yellow) Lights:**
- 2.15 Install the Interface Circuit for a PWM Backlight System (Optional):**
- 2.16 Install the USB-6A (Optional):**
- 2.17 Install the FM-SC or AC-1 Converter (Optional):**
- 2.18 Install any Additional Modules (Optional):**
- 2.19 Installing the EDC-33P:**

2.1 Important Information and Initial Checkout:

- A. **The installer and aircraft owner must read the Warranty/Agreement before starting the installation.** There is information in the Warranty/Agreement that may alter your decision to install this instrument. **If you do not accept the terms of the Warranty/Agreement, do not install this instrument.**
- B. **If you are not an FAA Certified Aircraft Mechanic familiar with the issues of installing engine and aircraft instruments, do not attempt to install this instrument.** The installer should use current aircraft standards and practices to install this instrument (refer to AC 43.13).
- C. **Check that any necessary FAA Approvals for installing this system are available for your aircraft before starting the installation.** The STC and AML is located at the back of this manual. Only one CGR-30P should be installed per engine.
- D. **Check the red, yellow and green limits in the “CGR-30P Configuration” document (provided with the kit). Match the aircraft POH/AFM for each function monitored by the CGR-30P. It is important the CGR-30P is properly configured for the engine and aircraft it is to monitor.**
- E. Read the Installation Instructions entirely and resolve any issues you may have **before** starting the installation. This may eliminate any delays once the installation is started.
- F. Inspect the contents of this package prior to installation. **If the CGR-30P system is to be installed into a certified aircraft, check that the Model Number listed on the TSO label incorporates the Aircraft ID for which it is to be installed. Each CGR-30P display is configured for a specific aircraft and should only be installed in that aircraft.**
- G. **Do not install a non-certified CGR in a certified aircraft.** A certified CGR lists the applicable TSO numbers at the bottom of the Model Label attached to the back panel of the CGR.
- H. **Before starting the installation make sure the instrument will fit in the intended installation location without obstructing the operation of any controls.** CFR 23.1321(a) states, *“Each flight, navigation, and powerplant instrument for use by any required pilot during takeoff, initial climb, final approach, and landing must be located so that any pilot seated at the controls can monitor the airplane’s flight path and these instruments with minimum head and eye movement.”* AC 23.1311 provides one method (but not the only method) of complying with this CFR. AC 23.1311 recommends a powerplant instrument be installed within a distance of 21" from the pilot’s visual centerline to the middle of the instrument. The pilot’s visual centerline is a perpendicular line from the pilot’s eye to the instrument panel. In most aircraft, installing the CGR-30P to the right of the Radio Stack would be acceptable. In some aircraft, the visual centerline falls to the right of the Attitude Indicator.

If the powerplant instrument cannot be installed within 8" of the pilot’s visual centerline, AC 23.1311 recommends Master Caution and Warning Lights be installed. Installation of Master Caution and Warning Lights is covered in this manual.
- I. If the CGR-30C is to replace an existing gauge in the aircraft, it is the installer’s responsibility to INOP or remove any duplicate instruments in the panel using FAA approved methods and procedures (see AC 43.13).
- J. An Installation Checklist is provided to assist the installation of the CGR system. It does not replace the instructions located in this manual.

2.2 Review the "EDC Wiring Work Sheets:"

There are a number of probes and extension cables that will need to be installed. The key to keeping the installation simple is to organize the work using the "EDC Wiring Work Sheets" supplied with this kit. Review the functions assigned to each EDC input on the EDC Wiring Work Sheets. The work sheets are prepared at the factory with the functions and probes already assigned.

2.3 Verify You Have all the Probes, Modules, Transducers and Cables:

The three EDC 37-pin D-sub connectors and the CGR 25-pin D-sub connector are pre-wired at the factory. The three EDC connectors are marked Top, Middle and Bottom. The EDC Wiring Work Sheets provide a list of the probes supplied with this kit.

- A. Check that you have all the probes listed on the EDC Wiring Work Sheets.
- B. Check that the three EDC 37 pin-D-sub wire harnesses are provided with the proper wires for each of the probes shown on the EDC Wiring Work Sheets.
- C. Check that the CGR 25-pin D-sub wire harness is provided.

2.4 Install the CGR Display:

Before starting the installation make sure the instrument will fit in the location you intend to install it without obstructing the operation of any controls. Also, the pilot should have a clear view of the CGR display without any visual obstructions. The CGR display is installed from behind the panel into a standard 3 1/8" hole. The mounting holes in the face of the CGR-30P have a limited depth. If the mounting screws are driven beyond the depth of the mounting holes, damage to the color display will occur. Mounting screws are provided in the package. These screws must be tightened by hand. If the screws tighten up before the faceplate secures against the panel, the screws are too long and must be shortened.

CFR 23.1321(a) states, *"Each flight, navigation, and powerplant instrument for use by any required pilot during takeoff, initial climb, final approach, and landing must be located so that any pilot seated at the controls can monitor the airplane's flight path and these instruments with minimum head and eye movement."* To comply with this requirement mount the CGR-30P 21" or less from the pilot's visual centerline to the middle of the instrument. The pilot's visual centerline is a perpendicular line from the pilot's eye to the instrument panel. In some aircraft, the visual centerline falls to the right of the Attitude Indicator.

If the CGR display is not installed within 8" of the pilot's visual centerline, the external Master Caution and Warning Lights should be installed. Installation of Master Caution and Warning Lights are covered in this manual.

Important Notice: Install the CGR display in the panel using the supplied 6-32 x 1/4 screws. Longer screws will damage the display. Hand tighten the screws. Check the screws are tight against the panel before they bottom out. Driving the screws through their stops will damage the display.

2.5 Install the Temperature Probes:

Install only the Temperature Probes applicable for your configuration.

A. EGT Probe Installation:

Look at each exhaust stack and determine the best location at which all of the EGT probes can be mounted at the same distance down from the exhaust ports. The ideal location is 1 1/2", but ease of installation should prevail. For our fast response probes drill a 5/32 hole or for our robust probes drill a 13/64" diameter hole in each exhaust stack. Insert the probe and tighten the hose clamp. As the hose clamp is heated and cooled, it will become loose as it conforms to the exhaust stack. After the first 10 hours of operation, each hose clamp should be retightened.

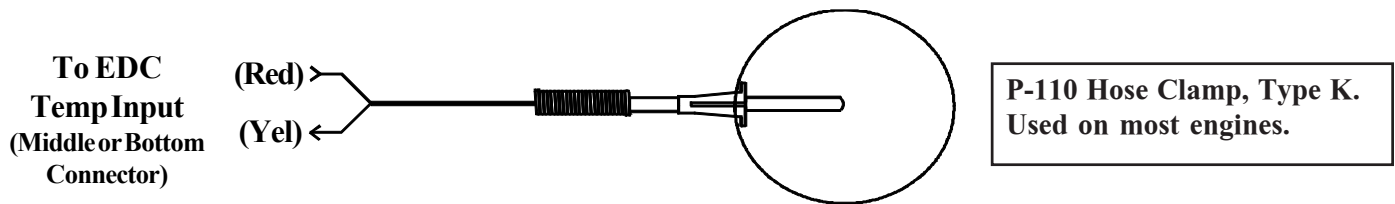

IMPORTANT NOTE: For Cessna 210s or any aircraft having a slip joint in the exhaust system, install the EGT probes ABOVE OR BELOW THE SLIP JOINT. Installing an EGT probe in the slip joint can damage the probe.

B. TIT Probe Installation:

The TIT probe should be installed on the inlet of the Turbocharger one to two inches before the Turbocharger flange. Look at each exhaust stack and determine the best location to install the TIT probe. It should be routed away from the exhaust pipe and should not come in contact with other aircraft components. When installing our fast response probes drill a 5/32 hole or for our robust probes drill a 13/64" diameter hole in each exhaust stack. Insert the probe and tighten the hose clamp.

If a P-111, P-112 or P-114 TIT probe is to be installed, perform the steps outlined in the "TIT Probe Depth Adjustment Procedure" that comes with the TIT probe.

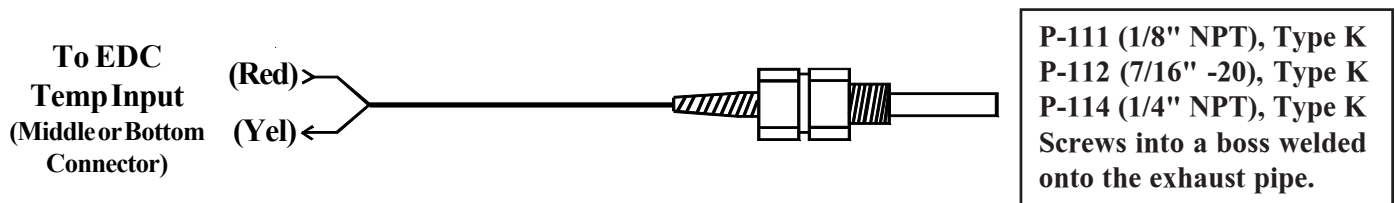

NOTE: After the first 10 hours of operation, the hose clamp on the P-110 probe should be retightened. As the hose clamp is heated and cooled, it will become loose as it conforms to the exhaust stack.

C. CHT Probe Installation:

Most engines have threaded ports for the CHT probes just below the lower spark plug. Install the CHT probes into these threaded ports.

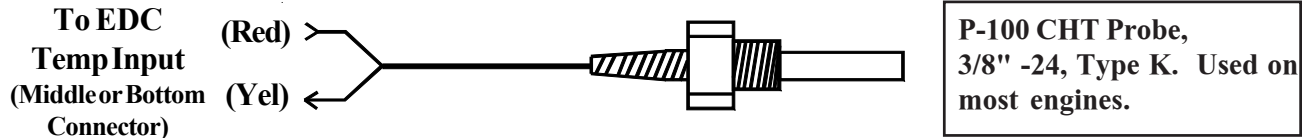

D. OIL Temperature Probe Installation:

Oil temperature can vary throughout an engine. Your engine's oil temperature specifications are based on a specific location of the oil temperature probe. If the CGR is to be used as the primary oil temperature instrument, install the oil temperature probe (P-120) in the primary oil temperature pick up point for your engine.

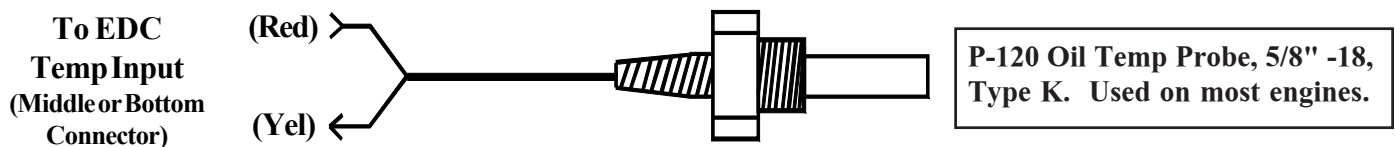

E. Carb Temp Probe Installation:

Remove the threaded plug located in the carburetor housing just below the throttle valve. Install the Carburetor Temperature Probe (P-128) in this hole using a lock washer. Care should be taken not to over-tighten the probe, thereby stripping the threads in the carburetor housing.



F. OAT Probe Installation:

Mount the OAT Probe in an appropriate location on the aircraft, using the hardware supplied. The OAT Probe is sensitive to air temperature changes. For this reason, do not mount the OAT probe in the path of the cowl or engine exiting air (i.e., on the belly of the aircraft). Also, if the probe is mounted in the cowling area near a turbo or hot cylinder head, radiant heat may influence the probe temperature. Other than these considerations, the OAT Probe may be mounted in an air intake vent, on the side of the cowling or anywhere else on the aircraft.

G. Other Temperature Probe Installation:

Other temperature probes (Cowl Temp, CDI Temp, Water Temp, etc.) may be installed using current aircraft standards and practices (refer to AC 43.13). Make sure these probes do not interfere with the operation of the engine or aircraft.

2.6 Install the Pressure Transducers:

Install only the Pressure Transducers applicable for your configuration.

A. Manifold Pressure Transducer Installation:

Mount the PT-30ABS Pressure Transducer on the inside firewall or in the equipment bay under the aircraft instrument panel. Use the holes in the bottom plate to mount the PT-30ABS. Only two mounting holes are required.

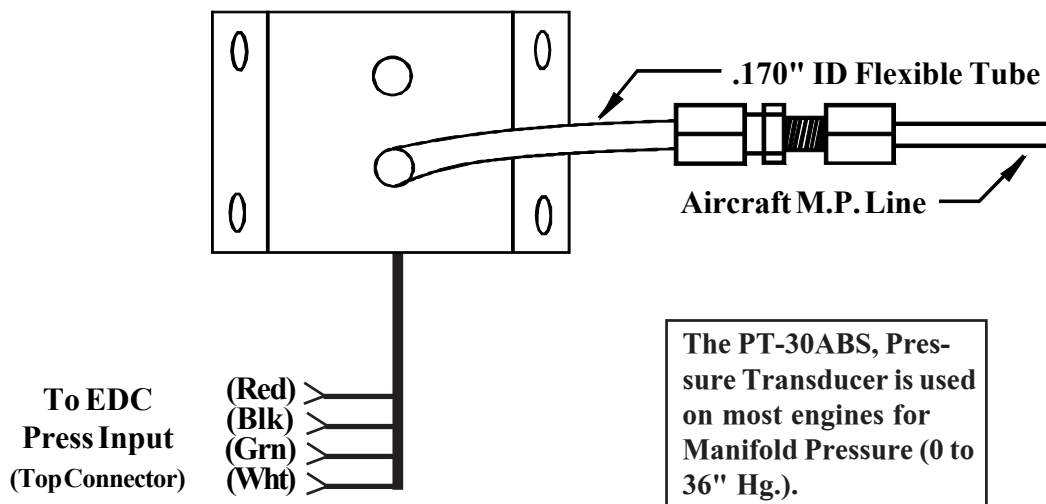

An equipment bay can be made from a sheet of aluminum. Any piece of equipment or module used with the CGR-30P can be mounted on the aluminum sheet using a Nut Plate or Riv-Nut to allow easy installation and removal. The aluminum sheet is then mounted to the inside firewall of the aircraft (using short spacers) and should never have to be removed. Many aircraft are designed with an equipment bay.

Connect the aircraft manifold pressure line to the pressure port on the PT-30ABS Pressure Transducer. A flare or barb fitting may be used to connect these lines. Care should be taken not to put excess pressure on the flexible line leading to the pressure transducer. **Make sure there are no kinks in the flexible pressure lines.**

Note: Many certified aircraft have a very small hole in the manifold pressure line to create airflow back to the intake manifold. This small flow of air keeps fuel from working its way into the manifold pressure gauge (or transducer), which can cause damage to the transducer over time.

Note: The PT-30ABS can measure manifold pressure up to 36.0" Hg. For manifold pressures above 36.0" Hg. use the PT-60ABS pressure transducer.

B. Gyro Vacuum Pressure Transducer Installation:

Mount the PT-05Diff Pressure Transducer on the inside firewall or in the equipment bay under the aircraft instrument panel. Use the holes in the bottom plate to mount the PT-05Diff. Only two mounting holes are required.

Connect the aircraft gyro vacuum line to the port tagged "Vac" on the PT-05Diff. Connect the port tagged "Press" to the aircraft overboard pressure line. A flare or barb fitting may be used to connect these lines. Care should be taken not to put excess pressure on the flexible line leading to the pressure transducer. **Make sure there are no kinks in the flexible pressure lines.**

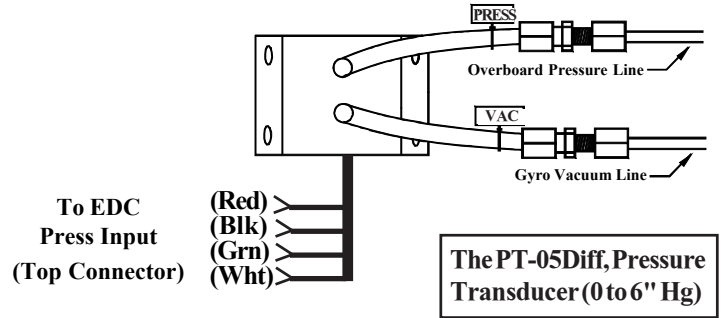

C. Oil Pressure Transducer Installation:

Find a convenient location on the firewall or a bracket and mount the pressure transducer with the clamp provided. The oil pressure line does not have to be routed into the cabin area, although you will need access on the cabin side of the firewall to tighten the pressure transducer clamp nut. **Do not mount the pressure transducer to an engine baffle or directly on the engine with the transducer supported by an adapter or fitting.** Vibration can cause the adapter to break, resulting in loss of engine oil. The pressure transducer is equipped with an 1/8" NPT male port. This port can be adapted to any oil pressure line. Use only a flexible hose and fittings suitable for aircraft use. Route a flexible oil pressure line from the primary oil pressure pickup point to the pressure transducer and tighten all fittings. **Do not use the case of the pressure transducer to tighten the pressure fittings.** Maintain any restrictive orifice currently in the system.

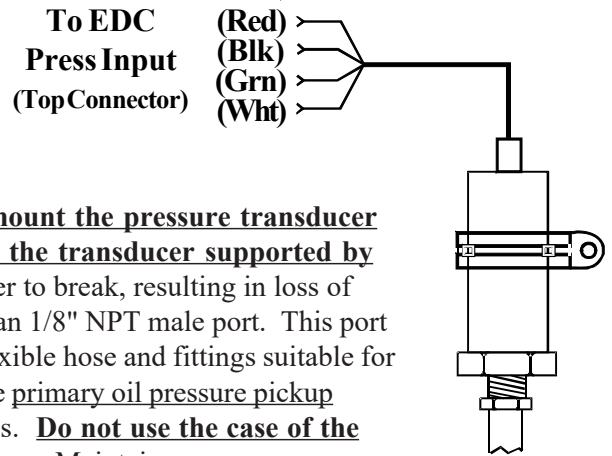

The PT-100GA Pressure Transducer is used on most engines for pressures up to 120 psi.

Some fittings you may want to consider using are listed below:

Important Note: Aluminum fittings should only be used when flex lines are mounted on the inlet of the pressure transducer. Otherwise, steel, SS or brass fitting should be used.

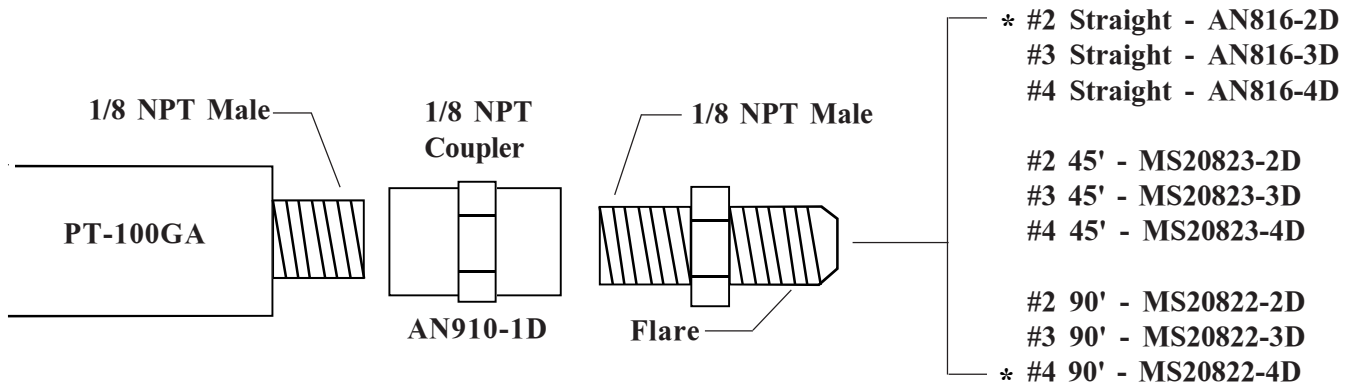

D. Fuel Pressure Transducer Installation:

Find a convenient location on the firewall or a bracket and mount the pressure transducer with the clamp provided. The fuel pressure line does not have to be routed into the cabin area although you will need access on the cabin side of the firewall to tighten the pressure transducer clamp nut. **Do not mount the pressure transducer to an engine baffle or directly onto the engine with the transducer supported by an adapter or fitting.** Vibration can cause the adapter to break, resulting in loss of engine fuel. The pressure transducer is equipped with a 1/8" NPT male port. This port can be adapted to any fuel pressure line. Use only a flexible hose and fittings suitable for aircraft use. Route a flexible fuel pressure line from the primary fuel pressure pick up point to the pressure transducer and tighten all fittings. **Do not use the case of the pressure transducer to tighten the pressure fittings.** Maintain any restrictive orifice currently in the system.

* Some fittings you may want to consider using are listed above.

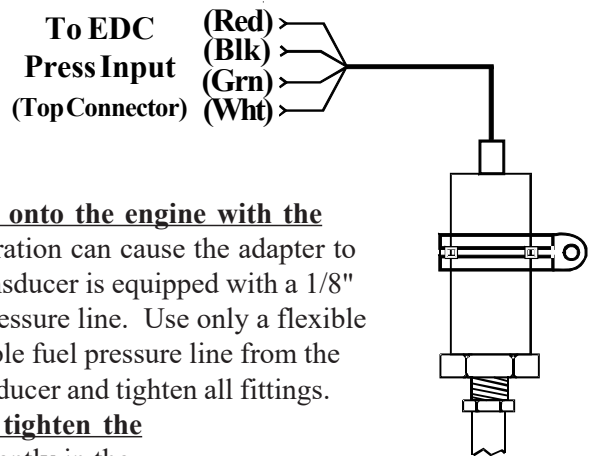

The PT-30GA Pressure Transducer is used on most engines for pressures up to 40 psi.

E. Other Pressure Transducer Installations:

Other pressure transducers should be mounted in the aircraft in the same manner as the Gyro Vacuum Transducer or the Oil and Fuel Pressure Transducers, as appropriate. **Note:** Any unused + or - pressure inputs must be wired to a ground pin on the EDC 37-pin connector.

2.7 Install the CO Detector, G-Sensor and/or Other Available CGR Options:

The CO Guardian Remote Mounted CO Detector, G-Sensor and other CGR options listed on EI's price sheet are provided with their own installation instructions. These items should be installed and wired in accordance with the accompanying instructions. Note: The CO Detector connects to Port 4 or Port 3 Input on the CGR.

2.8 Install the Shunt (for Amps):

An external shunt is a strip of metal, usually mounted on a bakelite base. This metal is made of special alloys to produce a very small, precise signal when current passes through it. It is not affected by temperature changes. If your aircraft currently has an external shunt you can calibrate your CGR to that shunt. The CGR can be calibrated to match any shunt on the market.

A. Determine How the Shunt will be Installed in the Aircraft's Electrical System:

There are two common methods of installing a shunt in an aircraft. One method is with the shunt in the alternator lead. The other method is with the shunt located in the battery lead. The S-50 shunt that comes with the CGR-30 package may be installed using either method. The advantages and disadvantages of each method are listed below.

There are few disadvantages with either method. Although EI's test pilot has a slight preference for the alternator lead when using the CGR, ease of installation should be the determining factor in this installation. If more than one shunt is required, a second shunt can be installed through a FM-VA-M-(50 or 300) Functional Module. The Functional Modules come with their own installation instructions.

Installation Method	Advantages	Disadvantages
Battery Lead:	<ol style="list-style-type: none"> Shows load current on the ground (engine off) and during an alternator failure. All Warning Lights are operational. 	<ol style="list-style-type: none"> Cannot show load current during flight or when the engine is running.
Alternator Lead:	<ol style="list-style-type: none"> Shows load current during flight or when the engine is running. All Warning Lights are operational. 	<ol style="list-style-type: none"> Cannot show load current when the engine is off or during an alternator failure.

S0224921

B. Install the External Shunt:

The external shunt should be installed in an appropriate location that minimizes the routing of main cables (refer to figure 1 or 2 as appropriate for your installation). It should also be mounted in a location where inadvertent damage cannot occur. If the shunt can be accessed easily, it should be covered. When mounting the shunt, use self-locking or safety-wired nuts.

Shunt

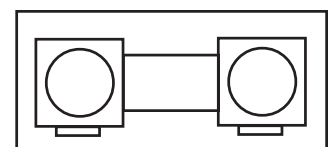

The signal wires from the shunt to the EDC must be fused a short distance after they leave the shunt. If this is a new installation, install two in-line one-amp fuses, one in each of the signal lines from the shunt to the EDC Amp Input.

Figure 1: External Shunt Installed in the Battery Lead

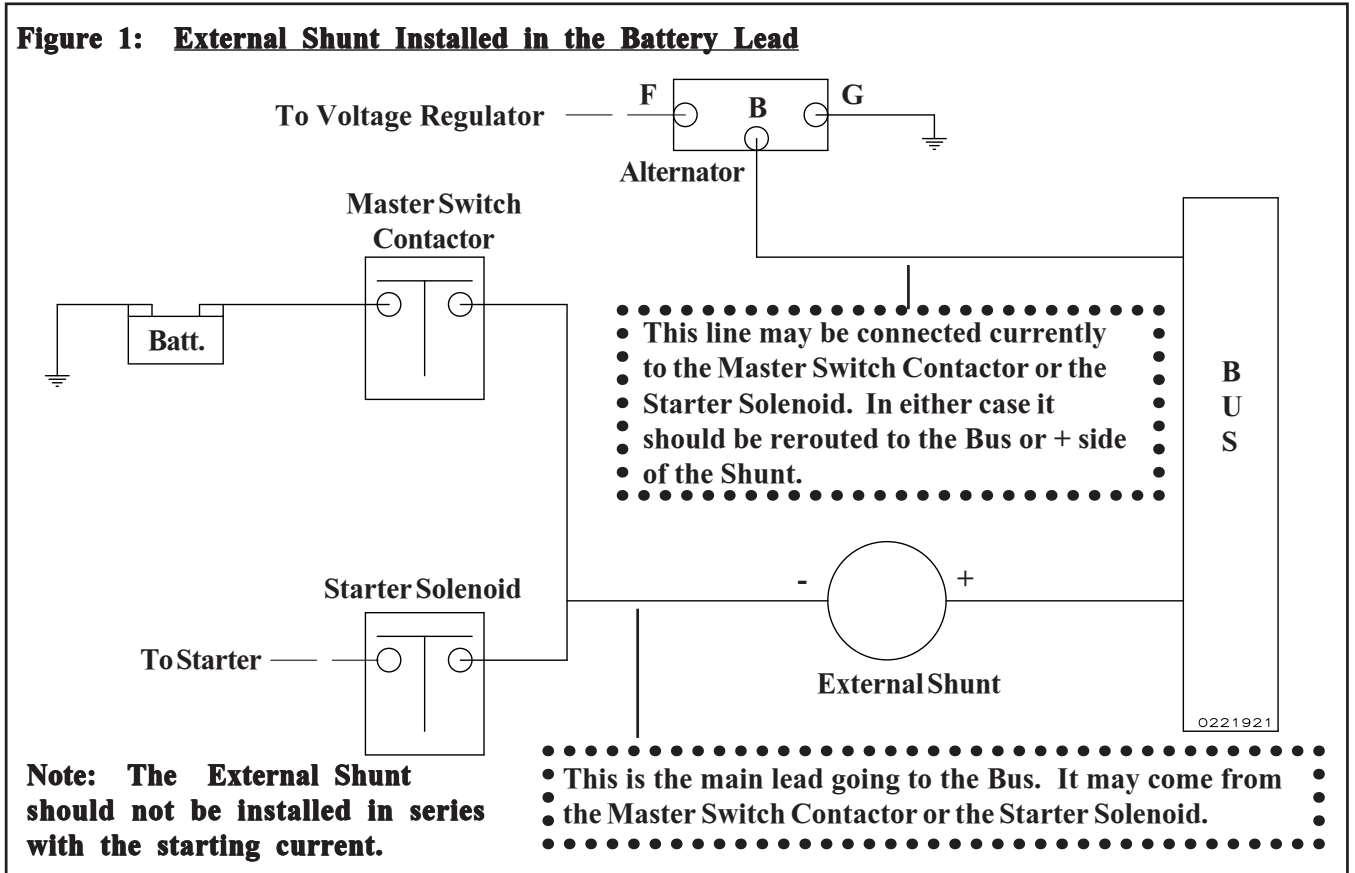

Note: If you are replacing an existing ammeter, the shunt may already be mounted in the aircraft. If you already have a shunt installed and know the value of the existing shunt, the CGR can be calibrated to that shunt.

Figure 2: External Shunt Installed in the Alternator Lead

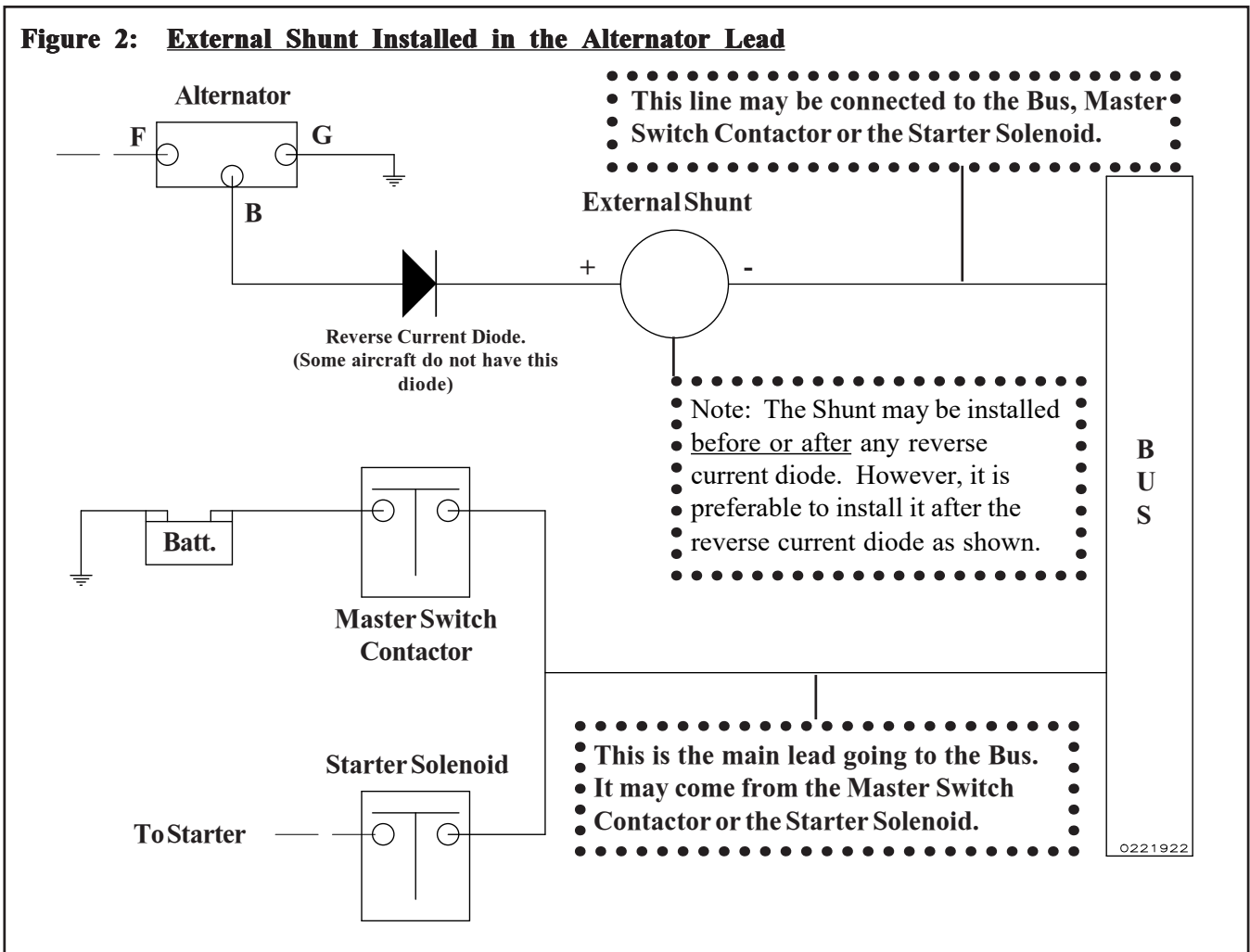

2.9 Install the Fuel Flow Transducer:

Mount the Fuel Flow Transducer using the appropriate drawing found on the following pages.

<i>Aircraft Configuration</i>	<i>Drawing #</i>
Fuel injected engine without a fuel return line from the fuel servo (most Lycomings).	1229932 or 1229931
Fuel injected engine with a fuel return line from the fuel servo (most Continentals).	0415941
Carbureted engine with a fuel pump and no fuel return line.	1229932 or 1229931
Carbureted engine with a fuel pump and a fuel return line (requires an FFDM-1 Module).	1229932 or 1229931, and 1015941
Carbureted engine with a gravity feed fuel system (requires an FT-90 Flow Transducer).	1229932 or 1229931

Fuel Flow Transducer Selection:

FT-60 (Red Cube): For 0 to 350 HP Engines.

FT-90 (Gold Cube): For 350 to 550 HP Engines or gravity feed fuel systems.

FT-180 (Black Cube): For 550+ HP Engines.

(See the transducer specification for pressure drops at a given flow rate.)

Note: If your engine is equipped with a pressure carburetor with a fuel return line from the carburetor back to the fuel tank, you will need to install two flow transducers: one in the feed line from the fuel pump to the carburetor and one in the return line from the carburetor back to the fuel tank. Also, a Fuel Flow Differential Module (FFDM-1) will need to be installed. See drawings 1229932 and 1015941 on the following pages.

Note: Insure the fuel flow transducer is appropriate for the horsepower of the engine.

- A. The transducer output port should be mounted lower, even with or no more than 4" per foot higher than the carburetor inlet port (or fuel servo on a fuel-injected engine). If this is not possible, a loop should be put in the fuel line between the Fuel Flow Transducer and the carburetor or fuel servo (see diagram below). This loop is intended to vacate air and keep it from getting trapped in the fuel transducer.
- B. Do not remove the yellow caps on the flow transducer until the fuel hoses are ready to be installed.

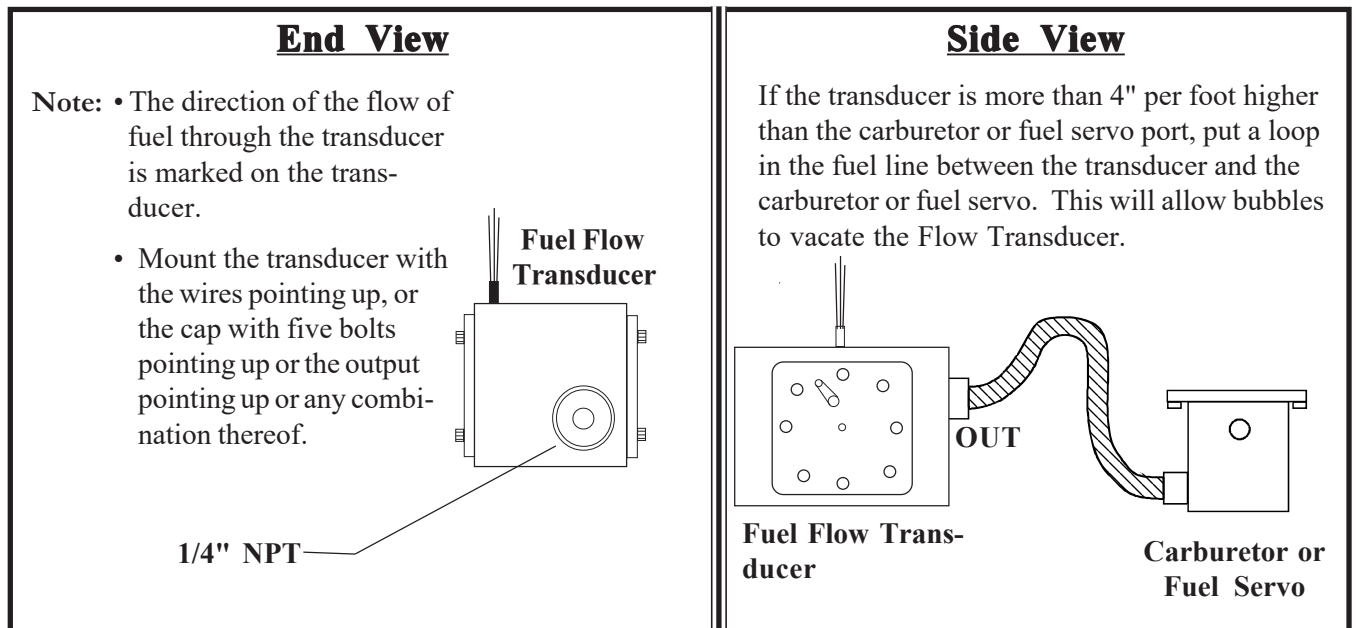

- C. The flow of fuel through the transducer must follow the direction marked on the transducer.
- D. The flow transducer must be mounted so the wires exiting the transducer are pointing up, or the cap with five bolts is pointing up, or the output port is pointing up, or any combination thereof.
- E. Before connecting any hoses, thoroughly clean them and insure they are free of any loose material. High air pressure may be used, **however, do not allow high air pressure to pass through the flow transducer.**
- F. When mounting a Fuel Flow Transducer, make provisions for the Fuel Pressure Transducer as necessary.

You may want to consider using some fittings and hoses shown below. Note: **DO NOT EXCEED a torque of 15 ft. lbs. or screw the fittings tighter than two full turns past hand tight, whichever happens first.**

Fittings:

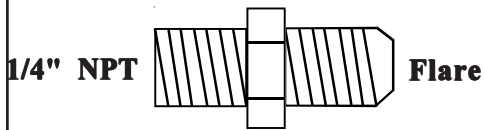

- #4 Straight - AN816-4-4D
- #6 Straight - AN816-6D
- #8 Straight - AN816-7D

#6 45' - MS20823-6D

#4 90' - MS20822-4-4D

#6 90' - MS20822-6D

Hose Fittings:

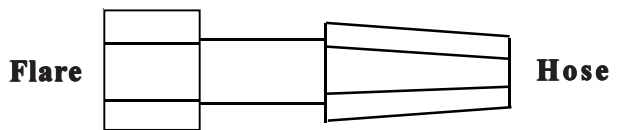

- Straight - MS24587-XX, Stratoflex 300-, Aeroquip 400-45' - MS27226-XX, Stratoflex 646- and 640, Aeroquip 980006
- 90' - MS27224-XX, Stratoflex 649- and 643, Aeroquip 980005

NOTE: The Stratoflex teflon hose can be much more flexible and easier to route than most existing hoses. If you have a hard-to-fit installation, you might want to consider this hose.

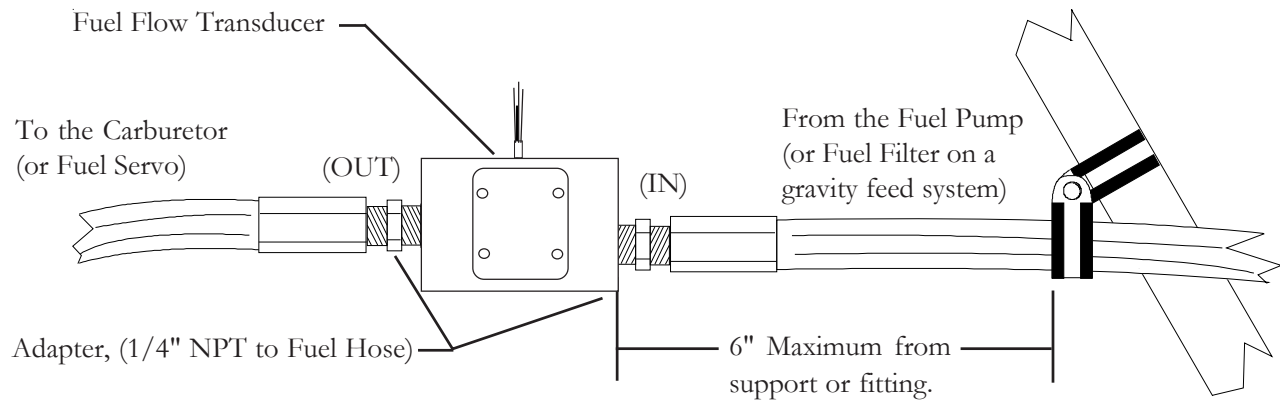

Mounting Procedure:

1. Find a convenient location within 6" of a hose support or fitting and away from any hot exhaust pipes to suspend the Fuel Flow Transducer. The hose support or fitting may be on the input or output line of the Flow Transducer and the support may be to an adjacent hose.
2. Remove the fuel hose which goes from the Fuel Pump (or the Fuel Filter on a gravity feed system) to the Carburetor (or Fuel Servo).
3. Purchase two new hoses: one to be used from the fuel pump (or the Fuel Filter) to the Fuel Flow Transducer and the other to be used from the Fuel Flow Transducer to the carburetor (or Fuel Servo). **There must be flexible hose in and out of the Transducer.** The hoses must meet TSO-C53a Type C or D FAA specifications. **The new hoses must be the same size as the current hoses in the aircraft.** Source of fittings and fabricated hoses are:

Aircraft Spruce
 aircraftspruce.com
 (877) 477-7823

4. Mount the Fuel Flow Transducer in the fuel line. **You must use the FT-90 (Gold Cube) Fuel Flow Transducer on a gravity feed system or for any engine over 350 H.P.** If the Transducer is mounted within 6" of an exhaust pipe, the Flow Transducer must be wrapped with Fire Sleeving.

5. Read the Installation Instructions for important installation considerations.

Drawn By:	R.R.	<i>Electronics International Inc.</i>		
Approved By:	R.R.	Installation of a Fuel Flow Transducer suspended in the fuel line <u>from the fuel pump to the carburetor or fuel servo.</u>		
Scale:	None	Note: <u>Not applicable</u> for a fuel-injected engine with a fuel return line (see D/N 0415941).		
Material:				
Next Assembly:				
P/N:		Date: 12/29/93	Rev: D: 7/2/02	D/N: 1229932

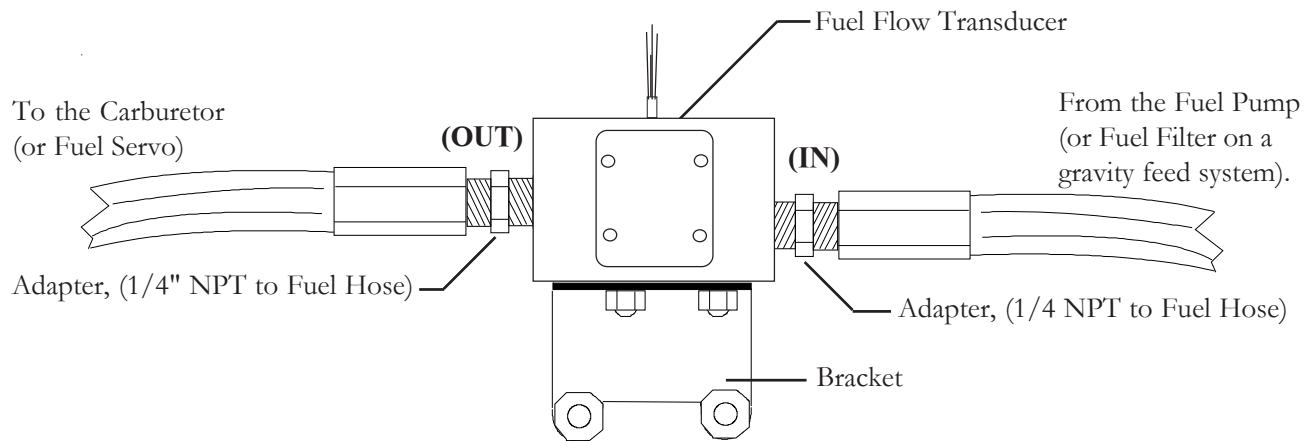

Mounting Procedure:

1. Find a convenient location on the firewall (away from any hot exhaust pipes) and mount a bracket for the Fuel Flow Transducer. Check both sides of the firewall for clearance before drilling any holes.
2. Mount the Fuel Flow Transducer onto the Bracket. **You must use the FT-90 (Gold Cube) Fuel Flow Transducer on a gravity feed system or for any engine over 350 H.P. If the Transducer is mounted within 6" of an exhaust pipe, the Flow Transducer must be wrapped with Fire Sleeving.**
3. Remove the fuel hose which goes from the Fuel Pump (or the Fuel Filter on a gravity feed system) to the Carburetor (or Fuel Servo).
4. Purchase two new hoses, one to be used from the fuel pump (or the Fuel Filter) to the Fuel Flow Transducer (making provisions for the fuel pressure transducer as necessary) and the other to be used from the Fuel Flow Transducer to the carburetor (or Fuel Servo). **There must be flexible hose in and out of the Transducer.** The hoses must meet TSO-C53a Type C or D FAA specifications. **The new hoses must be the same size as the current hoses in the aircraft.** Source of fittings and fabricated hoses are:

Aircraft Spruce
 aircraftspruce.com
 (877) 477-7823

5. **Read the Installation Instructions for important installation considerations.**

Drawn By:	R.R.			<i>Electronics International Inc.</i>		
Approved By:	R.R.			Installation of a Fuel Flow Transducer on the Firewall and in the fuel line <u>from the fuel pump to the carburetor or fuel servo.</u> Note: <u>Not applicable</u> for a fuel-injected engine with a fuel return line (see D/N 0415941).		
Scale:	None					
Material:						
Next Assembly:						
P/N:	Date:	Rev:	D/N:	12/29/93	D: 7/2/02	1229931

To the Flow Divider

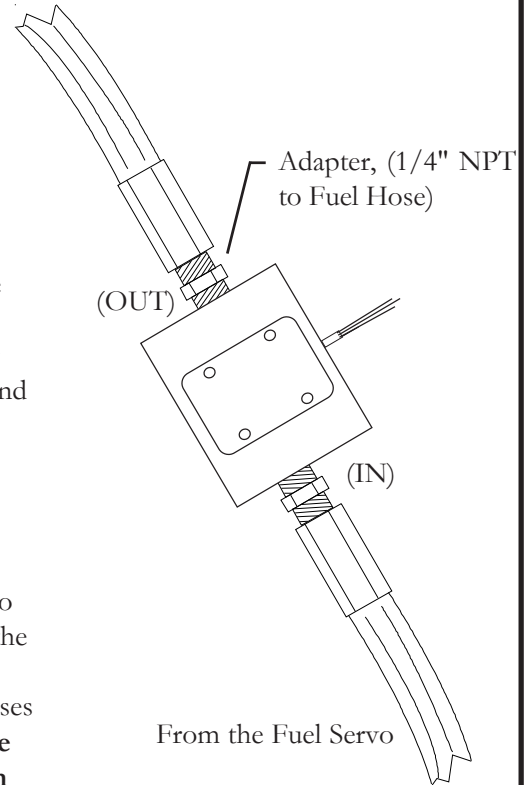

Mounting Procedure:

1. Find a convenient location between the Fuel Servo and Flow Divider and away from any hot exhaust pipes to suspend the Fuel Flow Transducer. The Transducer must be mounted within 6" of a hose support or fitting. The support or fitting may be on the input or output line of the Flow Transducer and the support may be to an adjacent hose.
2. Remove the fuel hose which goes from the Fuel Servo to the Flow Divider.
3. Purchase two new hoses: one to be used from the Fuel Servo to the Fuel Flow Transducer and the other to be used from the Fuel Flow Transducer to the Flow Divider. **There must be flexible hose in and out of the Fuel Transducer.** The hoses must meet TSO-C53a Type C or D FAA specifications. **The new hoses must be the same size as the current hoses in the aircraft.** Sources of fittings and fabricated hoses are:

Aircraft Spruce
 aircraftspruce.com
 (877) 477-7823

4. Mount the Fuel Flow Transducer in the fuel line. **You must use the FT-90 (Gold Cube) Fuel Flow Transducer on any engine over 350 H.P.** If the Transducer is mounted within 6" of an exhaust pipe, the Flow Transducer must be wrapped with Fire Sleeving.
5. **Read the Installation Instructions for important installation considerations.**

Drawn By:	R. R.	<i>Electronics International Inc.</i> Installation of the Fuel Flow Transducer suspended in the fuel line <u>between the Fuel Servo and the Flow Divider.</u> Note: <u>Only applicable</u> for installation on aircraft with a fuel return line from the Fuel Servo.					
Approved By:	R.R.						
Scale:	None						
Material:							
Next Assembly:							
P/N:		Date:	4/15/94	Rev:	B: 7/2/02	D/N:	0415941

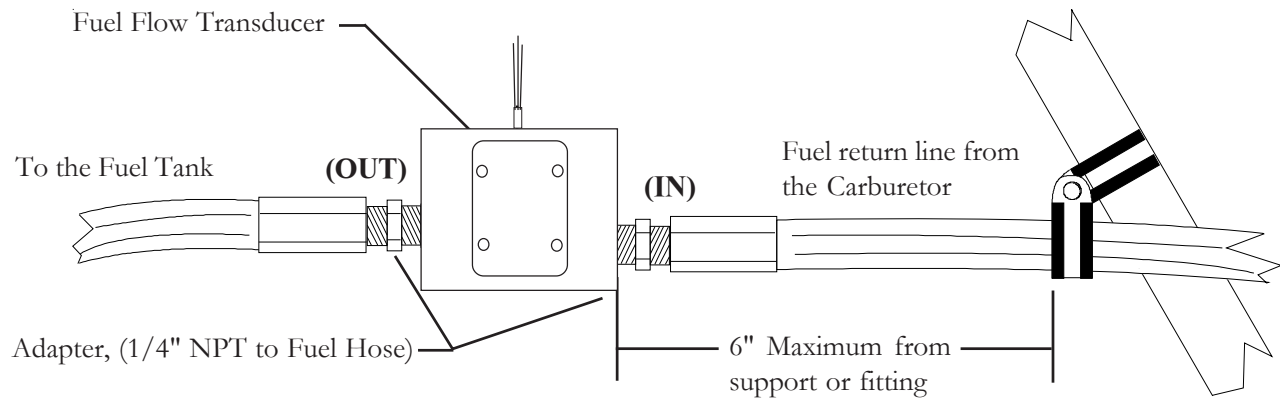

Mounting Procedure:

1. Find a convenient location within 6" of a hose support or fitting and away from any hot exhaust pipes to suspend the Fuel Flow Transducer. The hose support or fitting may be on the input or output line of the Flow Transducer and the support may be to an adjacent hose.
2. Remove the return fuel hose which goes from the Carburetor to the Fuel Tank.
3. Purchase two new hoses: one to be used from the Carburetor to the Fuel Flow Transducer and the other to be used from the Fuel Flow Transducer to the Fuel Tank. **There must be flexible hose in and out of the Transducer.** The hoses must meet TSO-C53a Type C or D FAA specifications. **The new hoses must be the same size as the current hose in the aircraft.** Source of fittings and fabricated hoses are:

Aircraft Spruce
 aircraftspruce.com
 (877) 477-7823

4. Mount the Fuel Flow Transducer in the fuel return line. **You must use the FT-90 (Gold Cube Fuel Flow Transducer on any engine over 350 H.P.** If the Transducer is mounted within 6" of an exhaust pipe, the Flow Transducer must be wrapped with Fire Sleeving.
5. Read the Installation Instructions for important installation considerations.

Drawn By: R.R.	<i>Electronics International Inc.</i>		
Approved By: R.R.	Installation of a Fuel Flow Transducer suspended in the <u>fuel return line</u> from the carburetor to the fuel tank.		
Scale: None	Note: <u>Only applicable</u> for installation on aircraft with a fuel return line from the <u>Carburetor</u> .		
Material:			
Next Assembly:			
P/N:	Date: 10/15/94	Rev: A: 7/2/02	D/N: 1015941

2.10 Install the EI P-300C Fuel Level Probes (OEM or Experimental Only):

Install the P-300C (Capacitive) Fuel Level Probes in accordance with the aircraft manufacturer's instructions.

2.11 Install the EI P-300M Fuel Level Sender:

The CGR-30 system can interface with an aircraft's existing Resistive Fuel Sensors via the RFLM-4 or these resistive fuel level sensors can be replaced with the P-300M (Magnetic Float) Fuel Level Sender. The signal produced by the P-300M Sender is a linear voltage output designed to work with the CGR-30 system.

The P-300M's float arm and travel must match the aircraft's existing sender's arm and travel. Due to the lack of information from aircraft manufacturers, the existing sender may need to be removed from the aircraft and sent to Electronics International. In this way the P-300M's float arm and travel can be matched with the aircraft's existing sender. Contact Electronics International for further information.

The P-300M has the same bolt pattern as resistive fuel senders. The P-300M requires three wires to interface to the EDC (resistive senders only use one wire).

Note: Calibrating the CGR-30P to a fuel tank can compensate for nonlinearity in the tank's shape and nonlinearity in the resistive fuel level sensor. The CGR cannot correct for inconsistent or non-repeatable signals from resistive fuel level senders. Unfortunately, many older resistive fuel level senders (and in some cases, newer resistive senders) exhibit some of the following problems:

- Variation in the wiper-to-element resistance (CRV).
- Stick slip problems with bearings and wiper-to-element contact.
- Windup causing jumps in readings.
- Weak wiper tension.
- Loose or worn bearings, causing fluctuations in tension and resistance.
- Worn out wiper.
- Corroded wiper.
- Corroded or worn element.
- Build up of varnish on the wiper and element.
- Water logged floats.

If you find inconsistent or inaccurate fuel level readings (due to a defective resistive fuel level sender), you must have the sender replaced. Inaccurate readings can lead to a dangerous situation. The CGR-30P depends on the fuel level sender for accurate fuel level information. Read the "Important Notice" in the CGR Operating Instructions.

The P-300M is a float type fuel level sender that uses a magnet and pickup device to detect the float position and produce the signal for the CGR-30 system. The P-300M has no wiper or resistive element and there is no tension on the bearing surfaces. It is not subject to the many problems associated with resistive type senders. The P-300M has nothing to wear out or affect inaccurate fuel level readings. Also, the P-300M does not require electricity to flow through an element and wiper saturated in fuel, as is the case with resistive senders.

2.12 Install the Resistive Fuel Level Module (RFLM-4-X):

The RFLM-4 is a Resistive Fuel Level Module that provides pull-up resistors for 4 resistive fuel level sensors. This module is required to interface an EDC Resistive Fuel Level Input to a Resistive Fuel Sensor.

Warning: DO NOT connect an RFLM-4 to the output of an existing aircraft's Capacitive System, damage to the system may occur. The small output voltage of an existing capacitive system currently drives a fuel level gauge. This output wire should be routed to one of the resistive fuel level inputs on the EDC with NO connection to an RFLM unit.

There are two RFLM-4 modules available. The RFLM-4-12V operates on a 12-volt electrical system and the RFLM-4-24V operates on a 24-volt electrical system. The appropriate model must be used.

Mount the RFLM-4-X to the inside firewall or to an equipment bay under the aircraft instrument panel. Use the holes in the bottom plate to mount the unit. Only two mounting holes are required.

Note: For each Fuel Level Channel on the EDC you can use either the Resistive Input or the Capacitive Input, but not both.

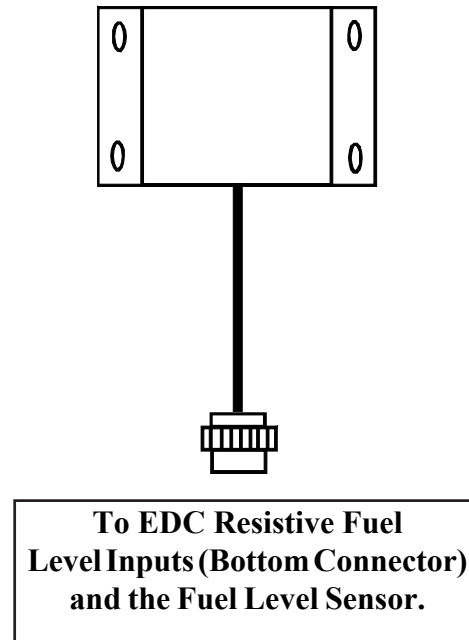

2.13 Install the Intensity Control Pot CP-1A (Optional):

The backlight display intensity of the CGR is controlled by an external source. The input voltage levels for a bright and dim setting on the CGR-30 are programmable. Your existing reostat can provide this signal or you may purchase the CP-1A.

The CP-1A Intensity Control Pot will provide the proper voltage for one or many CGR-30 units and for the external Master Warning and Caution lights associated with each instrument. To install the CP-1A perform the following:

- A. Find an appropriate mounting location on the aircraft instrument panel for the CP-1A Control Pot. The Pot will require a 2" clearance behind the aircraft instrument panel.
- B. Mark the aircraft instrument panel and drill a 1/4" hole for the Pot.
- C. Mount the Pot from behind the aircraft instrument panel and install the knob.

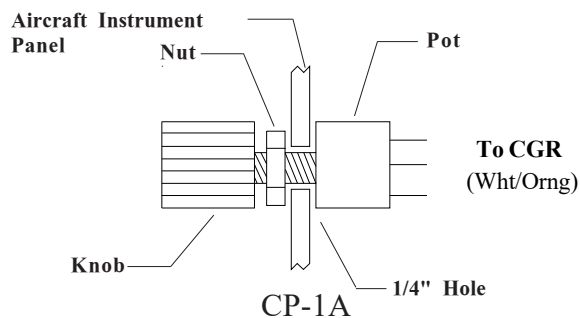

2.14 Install the Master Warning (red) and Caution (yellow) Lights:

Install the Warning and Caution Lights as follows:

- A. Locate the Red (AL-1R) and Yellow (AL-1Y) lights in the kit. Find an appropriate mounting location within 12" of the pilot's visual centerline. The lights will require 3/4" clearance behind the aircraft instrument panel.
- B. The CGR-30P remote lights and placard must be installed in a location where the placard will be readable in all lighting conditions. Installing the annunciators near an exiting lighting source or installing a post light are acceptable methods of compliance, other methods may also be acceptable.
- C. Mark the aircraft instrument panel and drill a 5/16" hole for each light. Install the Red Warning Light and the Yellow Caution Light from behind the aircraft instrument panel.

Note: If the CGR Master Warning and Caution Outputs are connected to other lights or devices, the current must be limited to 0.1 amps. The outputs pull to ground when active.

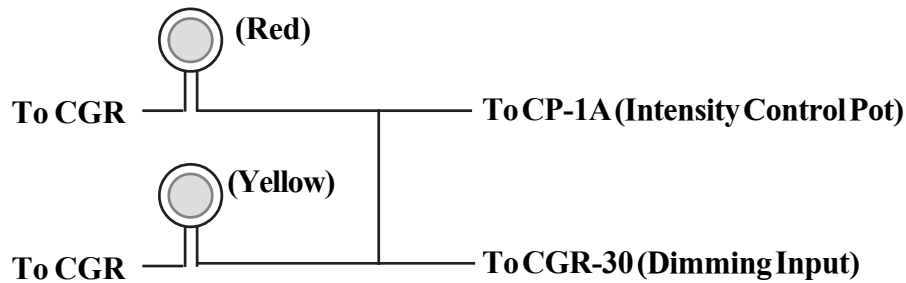

2.15 Install the Interface Circuit for a PWM Backlight System (Optional):

If a PWM backlight system will be used to control the CGR-30 screen intensity, place the following circuit in series with the CGR-30 backlight wire.

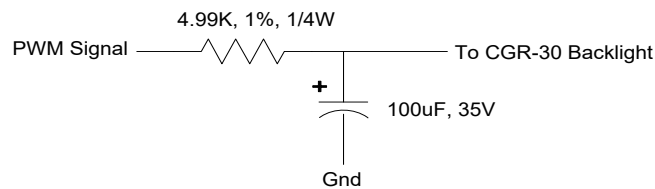

2.16 Install the USB-6A (Optional):

The CGR-30P provides a USB port to upload configuratoin data and to download flight data. The USB-6A allows the USB port to be mounted on the aircraft instrument panel. Otherwise, the port will only be available via a USB connector (dongle) located under the instrument panel. To install the USB-6A, following the instructions provided with the unit.

2.17 Install the FM-SC or AC-1 Converter (Optional):

The FAA PMA'd FM-SC and AC-1 are used to convert engine data from a FADEC unit to the CGR-30. To install the converter following the instructions provide with the appropriate unit.

2.18 Install any Additional Modules (Optional):

If any additional modules are provided with the system, install them at this time using the instructions provide with the modules.

2.19 Install the EDC-33P:

The EDC-33P (Engine Data Converter) converts all of the analog engine signals into serial data which is output to the CGR display via one wire (5V Serial). The EDC unit measures 4.5" long by 3.5" wide by 2.2" high. There are three 37-pin D-sub connectors that interface to the various probes, modules or direct connections to the aircraft.

Mount the EDC (with the connectors pointing down) on the inside firewall under the aircraft instrument panel or in an equipment bay with the connectors pointing down. For a twin-engine aircraft the EDC can be mounted on the opposite side of the firewall of the engine or in the cabin or equipment bay with the connectors pointing down. Use the holes in the bottom plate of the EDC to mount the unit. Be sure you will have enough room to connect the three D-sub connector wire harnesses to the EDC. Note: If you run out of channels on the EDC, a second EDC may be installed and connected to the CGR.

When routing the EDC wire harnesses refer to the Top, Middle and Bottom "EDC Wiring Work Sheets" found at the back of this manual. Insure no wires obstruct the freedom of travel of any controls.

Important Information - DO NOT lace the interconnect wires to the HV Spark Plug wires, P-leads or antenna wires. Also the interconnect wires should be routed away from the radio stack.

Install the EDC Wire Harnesses and Route Wires

- 3.1 Attach the three EDC 37-pin Wire Harnesses to the EDC:**
- 3.2 Connect the EDC Harness to the Temperature Probes:**
- 3.3 Connect the EDC Harness to the Pressure Transducers:**
- 3.4 Connect the EDC Harness to the Shunt:**
- 3.5 Connect the EDC Harness to the Fuel Flow Transducer:**
- 3.6 Connect the EDC Harness to the Existing Capacitive Fuel Level System:**
- 3.7 Connect the RFLM-4-x Harness to the EDC Connector and to the Resistive Fuel Level Sensors:**
- 3.8 Connect the EDC Harness to the EI P-300C Capacitive Fuel Level Probes:**
- 3.9 Connect the EDC Harness to the EI P-300M Magnetic Fuel Level Senders:**
- 3.10 Connect the EDC Harness (Volts Measurement Pin) to the Bus:**
- 3.11 Connect the EDC Harness to the RPM Signals:**
- 3.12 Set up the EDC for a 4 or 6-Cylinder Engine:**
- 3.13 Connect the EDC Harness to Power and Ground:**
- 3.14 Route the EDC 5V-Serial Wire to the CGR Connector:**

3.1 Attach the three EDC 37-pin Wire Harnesses to the EDC:

Secure the connectors using the supplied mounting screws.

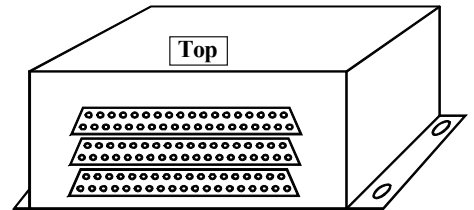

3.2 Connect the EDC Harness to the Temperature Probes:

Route each of the temperature cables in the EDC harness to the appropriate temperature probe. Cut the wires to length, install the appropriate connectors (see the “Working with Connectors” section of this manual for more information) and connect to the temperature probe. When connecting to a temperature probe, leave some slack in the cable exiting the probe to prevent damage to the probe over time.

All Type K Temperature Probes

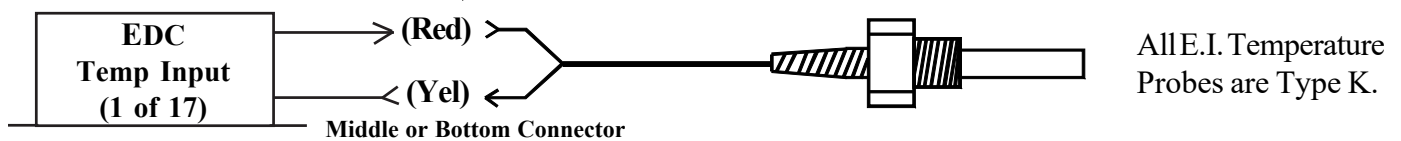

3.3 Connect the EDC Harness to the Pressure Transducers:

Route each of the pressure cables in the EDC harness to the appropriate pressure transducers. Cut the wires to length, install the appropriate connectors (see the “Working with Connectors” section of this manual for more information) and connect to the pressure transducer. When connecting to a pressure transducer, leave some slack in the cable exiting the transducer to prevent future damage to the transducer.

3.4 Connect the EDC Harness to the Shunt:

Route the EDC Amps wires to the Shunt. The way the Shunt is installed in the aircraft determines which lug will be used as "+" (see “Installing the Shunt” in the previous section of this manual). The EDC +Amp Input wire (green) should be connected to the small lug on the "+" side of the Shunt. The EDC -Amp Input wire (white) should be connected to the small lug on the "-" side of the Shunt.

PT-30GA, PT-100GA, PT300GA, PT-3000S Pressure Transducers:

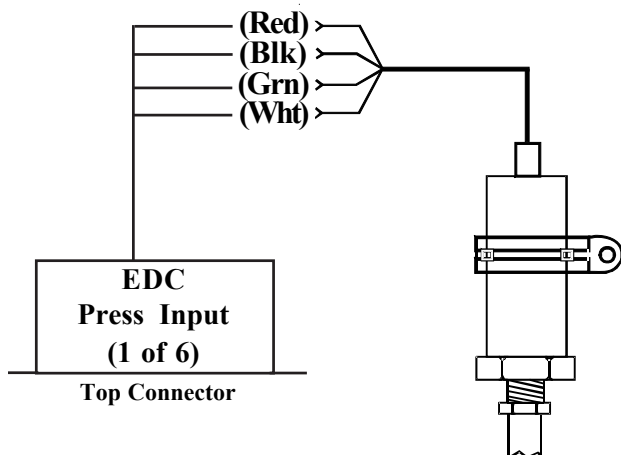

PT-30ABS, PT-60ABS, PT-05Diff, PT-04H20 Pressure Transducers:

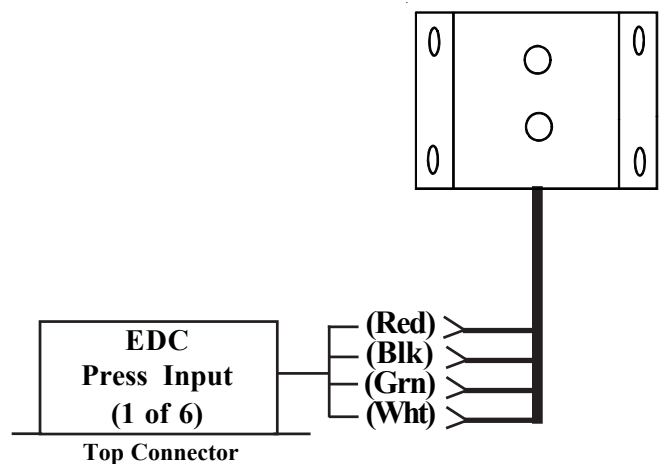

3.5 Connect the EDC Harness to the Fuel Flow Transducer:

Route the fuel flow cable in the EDC harness to the Fuel Flow Transducer. Cut the wires to length, install the appropriate connectors (see the “Working with Connectors” section of this manual for more information) and connect to the fuel flow transducer. When connecting to the Fuel Flow Transducer, leave some slack in the cable exiting the transducer to prevent future damage to the transducer.

If the flow transducer is hard mounted to a bracket, **DO NOT connect the Black Ground Wire** on the flow transducer. The bracket will provide the necessary ground to the transducer.

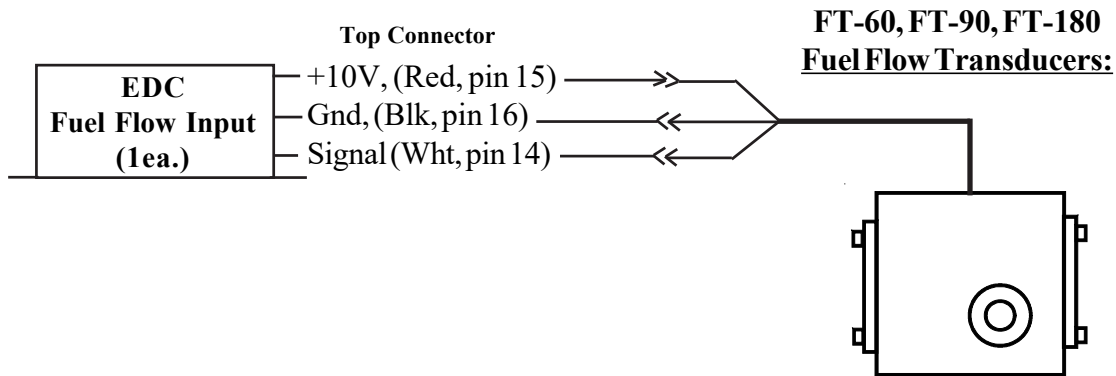

3.6 Connect the EDC Harness to the Existing Capacitive Fuel Level System:

The output signal of a capacitive fuel level system (on a certified aircraft) will have a wire connected from the capacitive system to the fuel level gauge. The signal on this wire will be 0 to approx 150mV DC. The other side of the gauge will be grounded. Re-route the signal wire (currently connected to the fuel level gauge) to one of the resistive inputs on the bottom connector of the EDC. **DO NOT connect an RFLM unit into this system as damage to the system may occur.** The current fuel level gauge must be removed from the system.

A 332-ohm resistor should be connected from the signal wire to ground. For a CGR-30 STC'd system, this resistor is integrated into the wire harness supplied with the system.

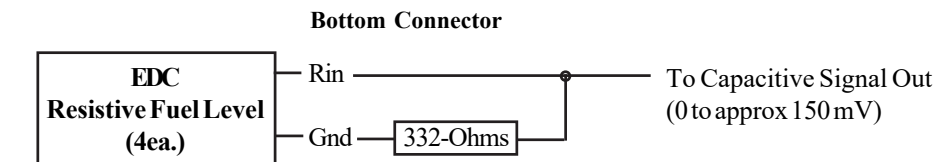

3.7 Connect the RFLM-4-x Harness to the EDC Connector and to the Resistive Fuel Level Sensors:

DO NOT connect the RFLM into a capacitive system as damage may occur. Route the appropriate resistive fuel level input wires (for the number of tanks to be monitored) in the RFLM-4-x harness to the EDC Bottom Connector. Plug the wires into the appropriate resistive fuel level channels. The excessive wire can be cut and spliced, bundled and tie-wrapped up or cut to length and new D-Sub pin installed (see the “Working with Connectors” section of this manual for more information). Route and connect the corresponding wires in the RFLM-4-x wire harness to the appropriate fuel tank sensors. Route the red wire (in pin 1 of the RFLM-4-x connector) to the aircraft bus via the CGR/EDC 5-amp circuit breaker.

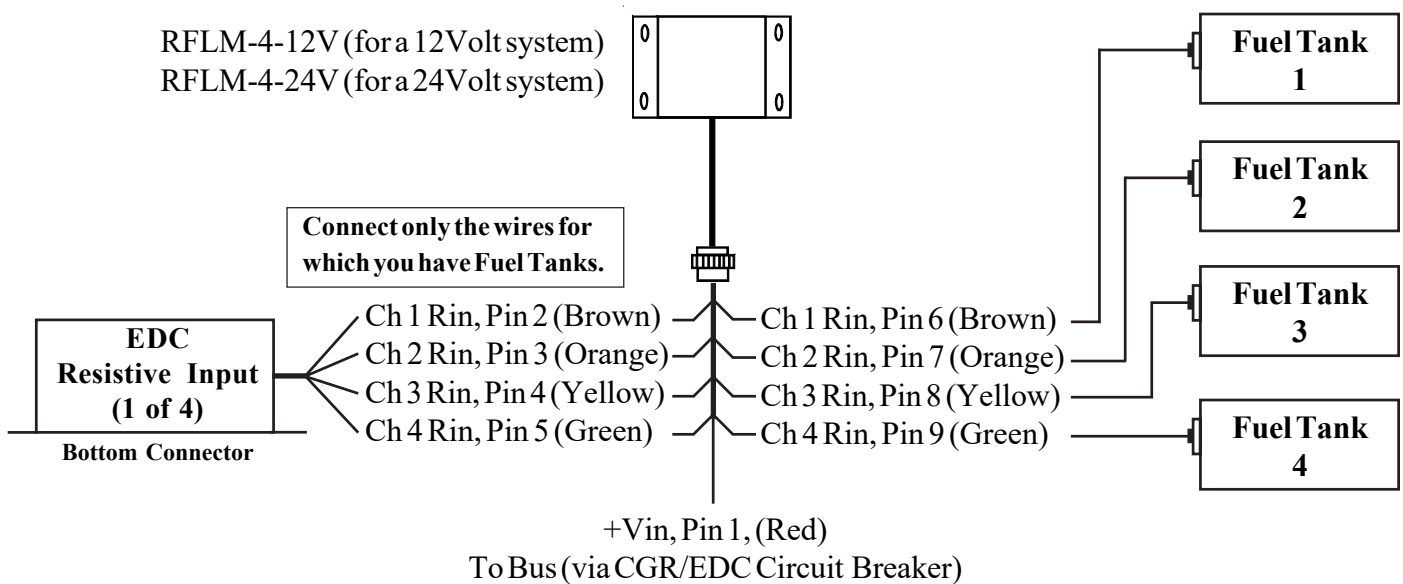

3.8 Connect the EDC Harness to the EI P-300C Capacitive Fuel Level Probes:

Route the appropriate capacitive fuel level wires (for the number of tanks to be monitored) in the EDC harnesses to the capacitive fuel level probes. Cut the wires to length, install the appropriate connectors (see the “Working with Connectors” section of this manual for more information) and connect to the capacitive fuel level probe.

Note: The capacitive fuel level channels are shared with the resistive channels. A single capacitive and resistive channel cannot be used simultaneously.

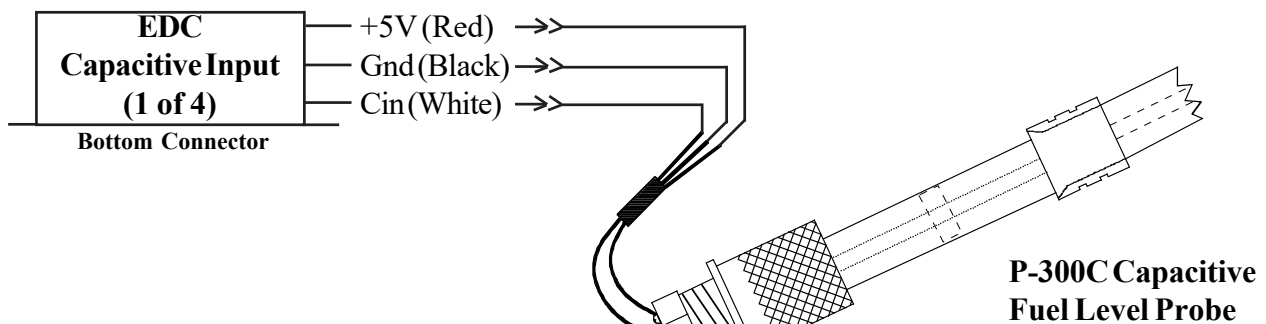

3.9 Connect the EDC Harness to the EI P-300M Magnetic Fuel Level Senders:

Route the appropriate fuel level wires (for the number of tanks to be monitored) in the EDC harnesses to the P-300M magnetic fuel level senders. Cut the wires to length, install the appropriate connectors and connect to the P-300M fuel level sender.

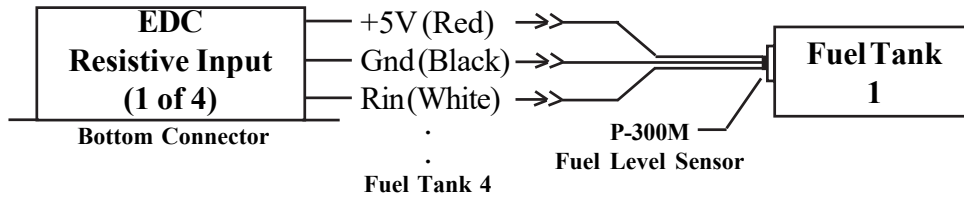

3.10 Connect the EDC Harness (Volts Measurement Pin) to the Bus:

Pin 35 of the EDC top connector monitors bus voltage. Connect this pin to the bus to be monitored.

3.11 Connect the EDC Harness to the RPM Signals:

If the EDC RPM Ch 1 and Ch 2 Inputs are to be connected to a Magneto, Ignition Coil or CDI Ignition System, connect the Ring Terminal Isolators (found in the RPM Isolator packet) to the P-leads on the back of the Mag Switch. Connect the EDC RPM Ch 1 and Ch 2 wires (White/Brown and White/Orange) to the RPM Isolators.

If the EDC RPM Ch 1 and Ch 2 Inputs are to be connected to an electronic ignition system, connect the EDC RPM Ch 1 and Ch 2 wires (White/Brown and White/Orange) directly to the electronic ignition system RPM output (do not use any isolators). Without isolators the EDC RPM Ch 1 and Ch 2 Inputs have a 3-volt trigger level and will accommodate 0 to 5-volt, 0 to 12-volt or 0 to 24-volt signals. If only one RPM signal is available, connect only one of the EDC RPM channels.

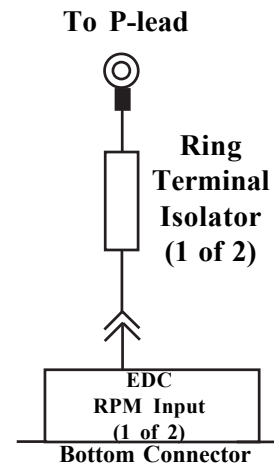

WARNING: Connecting an EDC RPM input directly to a magneto without an Isolator will damage the EDC. Be sure there is an Isolator in each RPM input lead connected to a magneto, ignition coil or CDI ignition.

3.12 Set up the EDC for a 4 or 6-Cylinder Engine:

If the EDC-33P is to be used on a 6-cylinder engine, strap Pin 28 to Pin 27 on the EDC Bottom Connector. Leave these pins open for a 4-cylinder engine. This strap may already be installed or can be found in the kit.

3.13 Connect the EDC Harness to Power and Ground:

Route the power wire (Top Connector, pin 37, Red Wire) to the CGR/EDC 5-amp Circuit Breaker. Route the ground wire (Top Connector, pin 19, Black Wire) to the aircraft ground.

WARNING: The power wire is RED and is connected to pin 37 on the EDC Top Connector. If aircraft power is connected to any pin on the EDC other than pin 37, damage to the EDC and any connected transducers may occur. Insure power is provided on pin 37 of the EDC Top Connector before attaching the connector.

3.14 Route the EDC 5V-Serial Wire to the CGR Connector:

Route the 5V-Serial white/green wire to the CGR connector. This wire will be connected to the CGR 5V-Serial input in a later step. If a second EDC is installed, see the Appendix for connection information.

When routing the CGR wire harness refer to the "CGR-30 25-pin D-Sub Connector Wiring Diagram" found at the back of this manual. Insure no wires obstruct the freedom of travel of any controls.

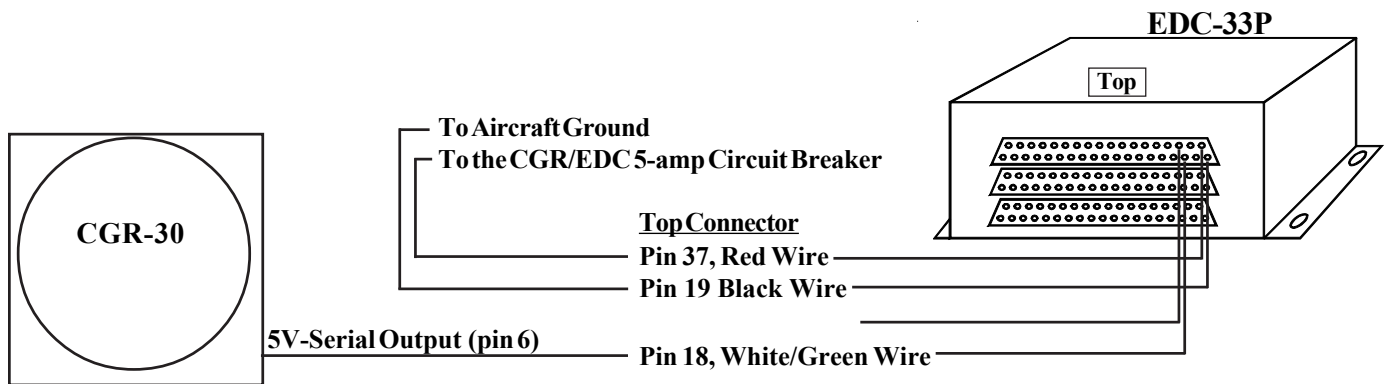

**Install the CGR Wire Harness
and
Route the Wires**

- 4.1 Attach the CGR 25-pin D-sub Connector to the CGR:**
- 4.2 Connect the EDC 5V-Serial Output Wire to the CGR 5V-Serial Input Wire:**
- 4.3 Connect the CGR Harness to the Master Warning and Caution Lights:**
- 4.4 Connect the CGR Harness to the Audio Panel (OEM Only):**
- 4.5 Connect the CGR Harness to the Backlight Control Pot:**
- 4.6 Connect the CGR Harness to the Moving Map Data Out from the GPS:**
- 4.7 Connect the CGR Harness to the Fuel Data Input on the GPS:**
- 4.8 Connect the CGR Harness to Power and Ground:**
- 4.9 Connect the CGR Harness to the CO-Guardian CO Detector:**

4.1 Attach the CGR 25-pin D-sub Connector to the CGR:

Secure the connector using the supplied mounting screws.

4.2 Connect the EDC 5V-Serial Output Wire to the CGR 5V-Serial Input Wire:

Route the EDC 5V-Serial output wire to the back of the CGR Display, cut the wires to length and splice them to the appropriate CGR 5V-Serial input wire.

4.3 Connect the Master Warning and Caution Circuits:

If the Warning and Caution Lights are installed, route the CGR Master Warning Out wire (White/Yellow, Pin 10) to the Master Warning (Red) Light (AL-1R) White wire, cut the wires to length, install the appropriate connector and connect to the AL-1R.

Route the CGR Master Caution Out wire (Yellow, Pin 23) to the Master Caution (Yellow) Light (AL-1Y) White wire, cut the wires to length, install the appropriate connector and connect to the AL-1Y.

Route and connect the CP-1A Backlight Control Pot to the CGR-30P and to the Master Caution and Warning lights.

Route the CP-1A Red wire to the CGR breaker. Route the Black wire to ground.

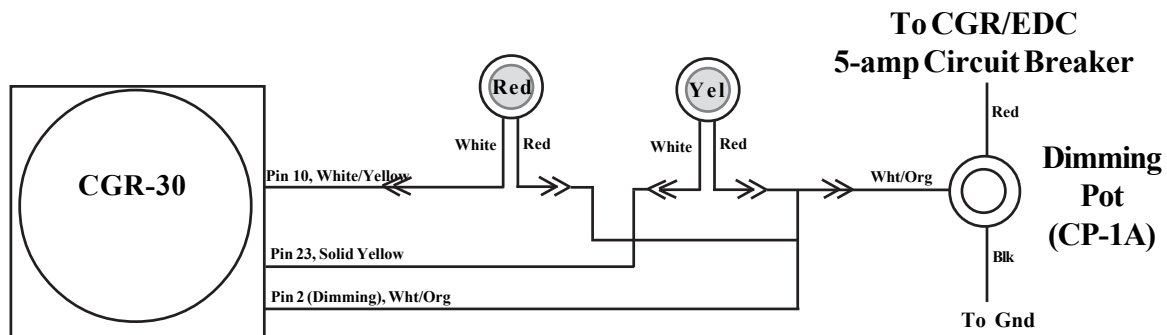

4.4 Connect the CGR Harness to the Moving Map Data Out from the GPS:

If the CGR is to provide fuel data to the current way point, route the CGR "Moving Map Data In" wire (green wire in a 4 wire cable) to the Moving Map Data Output Port on the GPS. Cut the wire to length, install the appropriate connector and connect to the GPS port.

4.5 Connect the CGR Harness to the Fuel Data Input on the GPS:

If the GPS is capable of displaying fuel data and this feature is to be used, route the CGR "Fuel Data Out" wire (white wire in a 4-wire cable) to the Fuel Data Input Port on the GPS. Cut the wire to length, install the appropriate connector and connect to the GPS port.

4.6 Connect the CGR Harness to Power and Ground:

Route the power wire (red) to the main bus via a 5-amp Circuit Breaker. Route the ground wire (black) to the aircraft ground.

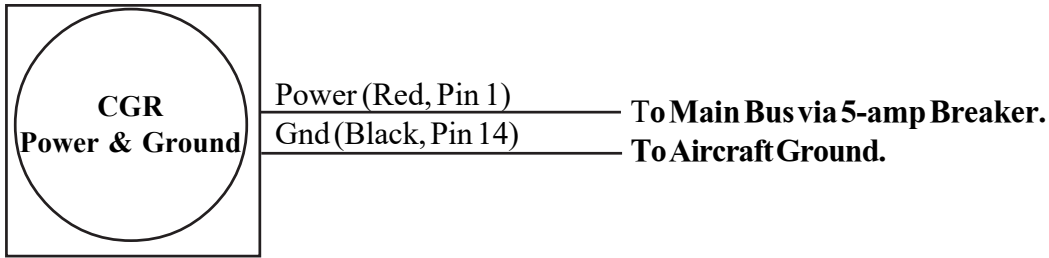

4.7 Connect the CGR Harness to the CO-Guardian CO Detector:

If a CO detector was installed, connect the RS232 output from the Remote Mounted 353-201 (experimental only) or 452-201-011 (certified) CO Detector to Pin 4 (Port 4 In) on the CGR. Refer to CO-Guardian’s installation instructions for further information on the CO Detector.

WARNING: The power wire is RED and is connected to pin 1 on the CGR. If aircraft power is connected to any pin on the CGR other than pin 1, damage to the CGR and any connected hardware may occur. Insure power is provided on pin 1 of the CGR before attaching the connector.

Mandatory System Setup and Checkout

5.1 Power-On Checkout:

5.2 Perform all Steps listed in the "CGR-30P Setup Checklist":

5.3 Ground Run Checkout:

5.4 First Flight Checkout:

5.5 Read the "Warranty/Agreement" and the "Important Notice":

5.1 Power-On Checkout

- A. Check the RPM for a reading of 000.
- B. Check the M.P. for the following reading:
Current BARO less 0.1"Hg for every 100 feet elevation above sea level.
- C. Check Fuel Flow for a reading of 00.0.
- D. Check Oil Pressure for a reading of 00.
- E. Check Oil Temp to read near ambient temperature.
- F. Check Volts for proper reading.
- G. Check Amps for proper reading.
- H. Check all EGTs to read near ambient temperature.
- I. Check all CHTs to read near ambient temperature.
- J. Check OAT to read ambient temperature.
- K. Check all other functions on the Main and System screens to operate properly.

Note: Fuel Levels may not read properly until they have been calibrated.

5.2 Perform all Steps listed in the "CGR-30P Installation Checklist":

A CGR-30P Installation Checklist is provided on blue tag board. Each step listed in this checklist must be completed before continuing with this installation.

5.3 Ground Run Checkout:

Start the aircraft engine. Check that the values for each function displayed on the CGR are proper for "engine on" operation. Any problem with a specific function will be associated with a probe, cable or interconnect cable between the probe and the EDC for that function. If you have a problem with any of the following steps, see the Troubleshooting section of this manual. Perform only the checks applicable to your configuration.

- A. Check the RPM.
- B. Check the M.P.
- C. Check Fuel Flow.
- D. Check Oil Pressure.
- E. Check Oil Temperature.
- F. Check Fuel Level for each Tank.
- G. Check Volts.
- H. Check Amps.
- I. Check all EGTs.
- J. Check all CHTs.
- K. Check OAT.
- L. Check all Annunciators.
- M. Check all other functions on the Main and System screens.

Turn the engine off. Inspect the entire system to be certain there is no interference with controls. Also, check for loose fittings, proper connections, clamps, probes, and inspect for leaks, chafing, obstructions, heat damage and anything that may cause unsafe flight. **Check that all fittings are tight.** Loose fittings can cause engine and/or aircraft damage and possibly personal injury.

5.4 First Flight Checkout:

Prepare the aircraft for flight. Fly the aircraft in the pattern. Check for proper operation of each function displayed on the CGR. Land the aircraft and perform the following checks as soon as possible:

- A. Check all fittings, hoses and transducers for leaks.
- B. Check all fittings, hoses, wires, system components and hardware to be secure and not chaffing.
- C. Check for interference to any controls.
- D. Check for any unsafe condition.

Do not release the aircraft for normal operation until all steps in this document have been performed and the aircraft is safe to fly.

5.5 Read the "Warranty/Agreement" and the "Important Notice":

Require the pilot to read the "Warranty/Agreement" and the "Important Notice" located in the front of the "Operating Instructions" before releasing the aircraft for flight.

Installation Data

6.1 Instructions for Continued Airworthiness (ICA):

6.2 Airworthiness Limitations:

6.3 Installing a D-sub Pin onto a TC or Tin Copper Wire:

CGR-30P Work Sheet, 25-pin D-sub Connector

EDC Wiring Work Sheet, Top Connector (Back View)

EDC Wiring Work Sheet, Middle Connector (Back View)

EDC Wiring Work Sheet, Middle Connector (Back View)

EDC Template

6.1 Instructions for Continued Airworthiness (ICA):

The Instructions for Continued Airworthiness (ICA) are located in the Electronics International document 06211301 "CGR-30P & CGR-30C Instructions for Continued Airworthiness". If you need an additional copy of the CGR-30P ICA please visit: www.iFlyEi.com or call (541) 318-6060.

6.2 Airworthiness Limitations:

The Airworthiness Limitations section is FAA approved and specifies maintenance required under CFR 43.16 and 91.403 of the Code of Federal Aviation Regulations unless an alternative program has been FAA approved.

Operational:

The conditions and tests required for TSO approval of the CGR-30 are minimum performance standards. It is the responsibility of those installing this system either on or within a specific type or class of aircraft to determine that the aircraft installation conditions are within the TSO standards. TSO articles must have separate approval for installation in an aircraft. The CGR-30 may be installed only if performed under 14 CFR part 43 or the applicable airworthiness requirements. There are no further specific operating limitations of this system.

Installation:

The CGR-30 system is to be installed in accordance with the current CGR-30 Installation Instructions, AC 43.13 and any other appropriate FAA approved practices or guidelines. These instructions along with FAA approved material insure the system will meet the requirements of the applicable TSOs once installed in an aircraft. There are no further specific installation limitations of this system.

6.3 Installing a D-sub Pin onto a TC or Tin Copper Wire:

D-sub pins are used in the D-sub connectors found on the EDC and the CGR. Most of these pins have already been installed on the appropriate wires and inserted into the proper connector. Installing a D-sub pin requires a D-sub crimp tool. Most electronic stores carry a reasonably priced D-sub crimp tool that will perform a good crimp but a 4 to 5 pound pull test must be performed. To install a D-sub pin onto a 20 ga. Tin Copper Wire, perform the following steps:

- A. Strip the insulation back 1/8." Be careful not to nick the wire.
- B. Insert the pin into the 24 ga. D-sub Pin Crimper. The crimpers have two cavities; the smaller one is used to crimp the bare wire and the slightly larger one is used to crimp around the insulation. Check that the pin is inserted into the crimpers properly. Also, the ears on the pin must be facing into the center of the crimp tool cavity to produce a good crimp. If the pin rotates even a little during crimping, the connection will be unreliable.
- C. Insert the wire into the pin. Check that the insulation

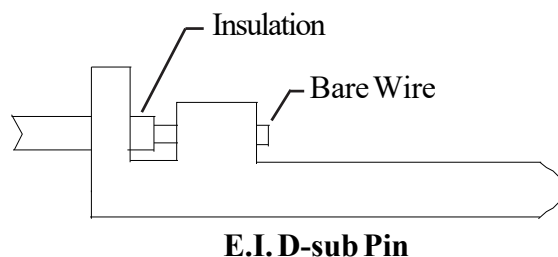

is in the strain relief crimp area but not in the bare wire crimp area. Crimp the pin onto the wire. **A good crimp is very important. Poor crimps will cause jumpy readings and are the biggest source of problems.**

- D. Pull Test: Pull (approximately 4 to 5 pounds) on the wire near the connector with one hand while holding the connector with the other hand. If the wire pulls out of the connector, you must start over using a new connector.
- E. A well soldered connection at the crimp can be reliable. Soldering a TC wire requires a lot of heat to produce a good solder connection. Also, when soldering a TC wire each wire should be scraped with a knife to expose fresh metal just before crimping and applying solder. Fluxing the TC wire can also help. Do not use acid core solder or acid flux.

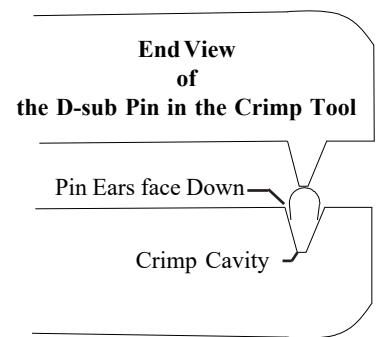

Troubleshooting the CGR system can be relatively simple. First the CGR must be powered-up. This requires only a power and ground connection to the CGR. Next the EDC needs to be powered-up and communicating with the CGR. Power and ground are supplied to the EDC on two wires and the EDC communicates with the CGR on one 5V-Serial wire. A "COM" error will be displayed if the EDC is not communicating with the CGR.

The rest of the system is made up of individual functions performing independently of each other. A problem with a pressure channel will most likely be found in the connection to the transducer, the wire from the transducer to the EDC or the EDC connection. This same scenario is true for all the functions. Rarely is there a problem with the EDC or CGR. In some cases the problem can be in the setup programming of the CGR.

CGR-30P

**CGR-30P
Work Sheet**
(DB25 Connector)

Aircraft ID:
SAMPLE

Back View, Wire Side

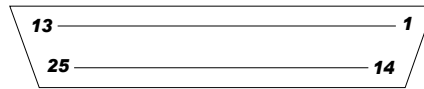

DB-25 (421-0331-00)
Pin (421-0301-00)

CGR-30P

	DB
Power In	1
Gnd	14
Port 1, Rx, 5V-Serial	6
Port 1, Tx, RS232	18
Port 2, Rx, 5V-Serial	7
Port 2, Tx, RS232	19
Gnd	5
Port 3, Rx, RS232	3
Port 3, Tx, RS232	15
Gnd	17
Port 4, Rx, RS232	4
Port 4, Tx, RS232	16
Master Warning Out	10
Master Caution Out	23
Gnd	20
	12
	13
	25
	11
	24
Back Light Control In	2
USB +5V	21
USB +	22
USB -	9
USB Gnd	8

FOR REFERENCE ONLY

AIRCRAFT SPECIFIC WORKSHEET
IS PROVIDED IN YOUR KIT

UNUSED PRESSURE INPUTS MUST BE
GROUNDED

EDC-33P

EDC Work Sheet Top Connector

Aircraft ID:
Sample

Notes:

***1 Unused Pressure Channel
Inputs Must Be Grounded.**

DB-37 Back View, Wire Side

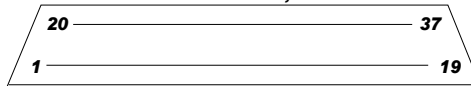

DB-37 (421-0337-00)
Pin (421-0301-00)

DB-25 CGR-30

EDC-33P

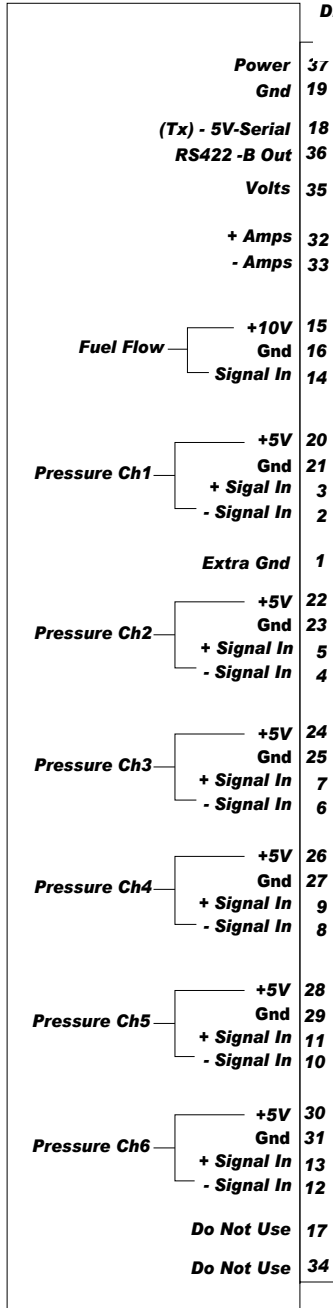

FOR REFERENCE ONLY

AIRCRAFT SPECIFIC WORKSHEET
IS PROVIDED IN YOUR KIT

UNUSED PRESSURE INPUTS MUST BE
GROUNDED

Electronics International Inc.

EDC Work Sheet Middle Connector

SAMPLE

Notes:

- *1 Unused Pressure Channel Inputs Must Be Grounded.
- Extra Gnds maybe used for shields.
- Unused Temp Channels may be used for annunciators.

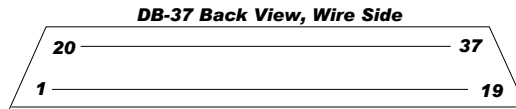

DB-37 (421-0337-00)
Pin (421-0301-00)

EDC-33P

	Extra Gnd	1
Temp Ch 1	+ In (Yel)	2
	- In (Red)	20
Temp Ch 2	+ In (Yel)	3
	- In (Red)	21
Temp Ch 3	+ In (Yel)	4
	- In (Red)	22
Temp Ch 4	+ In (Yel)	5
	- In (Red)	23
Temp Ch 5	+ In (Yel)	6
	- In (Red)	24
Temp Ch 6	+ In (Yel)	7
	- In (Red)	25
Temp Ch 7	+ In (Yel)	8
	- In (Red)	26
Temp Ch 8 (Best for OAT)	+ In (Yel)	9
	- In (Red)	27
	Temp Comp + In	10
	Gnd	28
	Extra Gnd	11
	Extra Gnd	12
Temp Ch 9	+ In (Yel)	13
	- In (Red)	31
	Extra Gnd	29
	Extra Gnd	30
Temp Ch 10	+ In (Yel)	14
	- In (Red)	32
Temp Ch 11	+ In (Yel)	15
	- In (Red)	33
Temp Ch 12	+ In (Yel)	16
	- In (Red)	34
Temp Ch 13	+ In (Yel)	17
	- In (Red)	35
Temp Ch 14	+ In (Yel)	18
	- In (Red)	36
Temp Ch 15	+ In (Yel)	19
	- In (Red)	37

FOR REFERENCE ONLY

AIRCRAFT SPECIFIC WORKSHEET
IS PROVIDED IN YOUR KIT

UNUSED PRESSURE INPUTS MUST BE
GROUNDED

EDC Work Sheet Bottom Connector

SAMPLE

Notes:

- *1 Unused Pressure Channel Inputs Must Be Grounded.
- Extra Gnds maybe used for shelds.
- Unused Res Fuel Level Ch's may be used for annunciators.

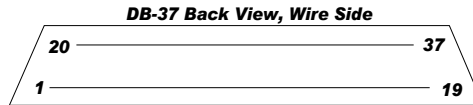

DB-37 (421-0337-00)
Pin (421-0301-00)

EDC-33P

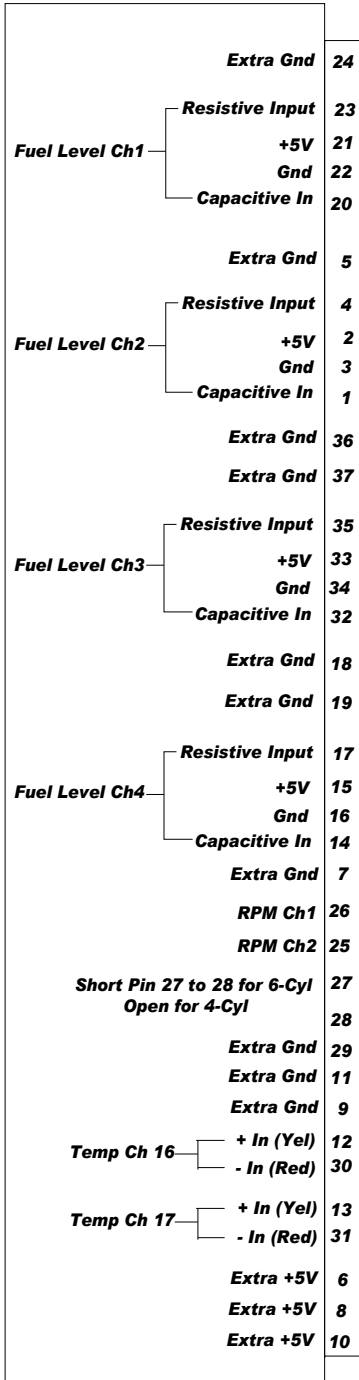

FOR REFERENCE ONLY

AIRCRAFT SPECIFIC WORKSHEET IS PROVIDED IN YOUR KIT

UNUSED PRESSURE INPUTS MUST BE GROUNDDED

EDC Template

0303071

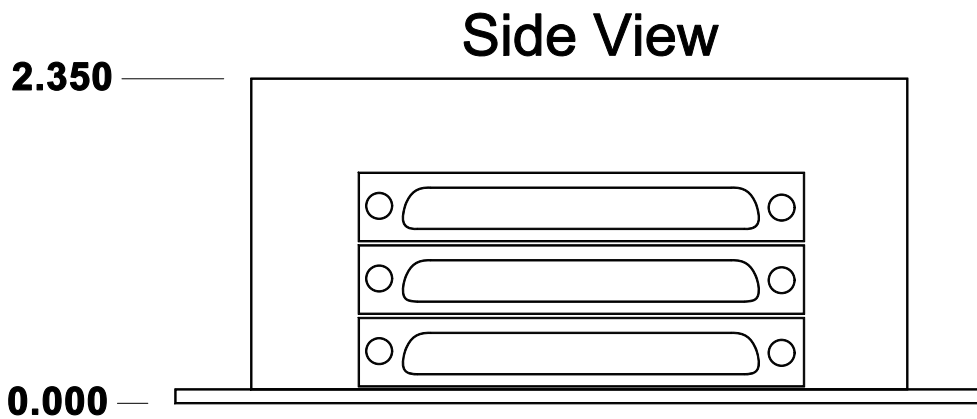
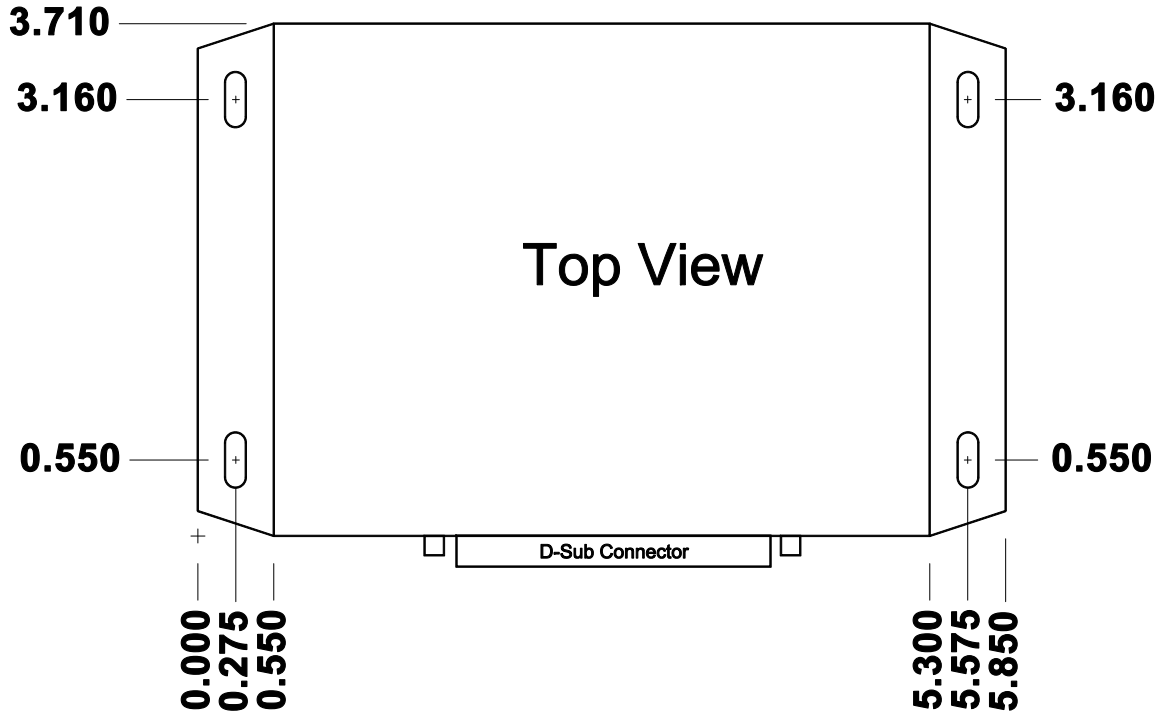

Troubleshooting

7.1 CGR or EDC Problem:

7.2 Pressure Problem with one Function:

7.3 Temperature Problem on all Channels:

7.4 Temperature Problem with one Function:

7.5 RPM Problem:

7.6 Fuel Flow Problem:

7.7 Amp Problem:

7.8 Resistive Fuel Level Problem:

7.9 Capacitive Fuel Level Problem:

7.10 Voltage Problem:

7.1 CGR or EDC Problem:

The CGR and EDC require power and ground to operate. The EDC also requires one 5V-Serial wire to communicate with the CGR. The EDC also supplies power to the Fuel Flow, Fuel Level, and Pressure Transducers. If these power wires become shorted, the EDC operation will be affected.

A. Symptom: The CGR does not power up.

1. Problem: The Power or Ground wire is open or not connected properly.

a) Action: Measure the voltage on the power and ground wires. Ohm the ground wire to ground. Look for a short.

B. Symptom: “COM” is displayed for the digital value for most functions. The EDC is not communicating with the CGR.

1. Problem: One of the EDC external +5 volt power supplies on the Bottom Connector is shorted to ground.

a) Action: Remove the Bottom Connector. If the COM error goes away, look for a short on one of the +5 volt wires.

2. Problem: The Power or Ground wire to the EDC is open or not connected properly.

a) Action: Measure the voltage on the appropriate EDC pins. Ohm the Black ground wire to ground.

3. Problem: The EDC +10 volt or one of the +5 volt supplies on the Top Connector is shorted to Ground.

a) Action: Measure the +10 volt and +5 volt supplies on the Top Connector. If one of the voltages is low, use an ohmmeter to find the problem. If all wires ohm properly (>100 ohm when disconnected from the EDC), the Power or Ground wire to the Top Connector may be open.

4. Problem: The 5V-Serial wire from the EDC to the CGR may be open.

a) Action: Inspect the wire. Remove the connectors from the EDC and the CGR and check for continuity.

Symptom: “REF” is displayed for the digital value for all temperature functions.

1. Problem: The Middle Connector on the EDC is loose or not connected. The Reference Diode on pins 10 and 28 of the EDC Middle Connector is damaged. Note: Pin 28 should measure 0 volts and pin 10 should measure around .6 volts.

a) Action: Inspect the EDC Middle Connector and measure the voltage on pins 10 and 28.

Symptom: “OVR” is displayed for the digital value for a function.

1. Problem: If a channel on the EDC is over ranged (>2.5 volts between the “+” and “-” inputs), an “OVR” will be displayed for that function. This can happen on a channel that is used to monitor an Annunciator, Flap or Trim function. The max input voltage for any temperature or pressure channel is +5 volts to ground. The maximum differential voltage is 2.5 volts. The VI-221 is

used to drop the voltage when measuring signals that switch from ground to bus voltage.

- a) Action: Measure the voltage on the EDC “+” and “-” inputs for the function with the problem.

7.2 Pressure Problem with one Function:

Pressure is measured on the aircraft with a pressure transducer. Power (+5 volts on the Red wire) and ground (Black wire) is supplied to the transducer and a differential signal (proportional to the pressure) is supplied to the EDC on the White and Green wires.

Symptom: Inaccurate, jumpy or zero reading.

1. Problem: One of the four wires from the Pressure Transducer to the EDC is open.

- a) Action: Measure the voltage on each transducer wire at the Pressure Transducer. The voltage on each wire is as follows: Red wire = +5 volts, Black wire = 0 volts, Green wire = 2.5 volts and White wire = 2.5 volts.

Short the Green wire to the White wire and look for a zero pressure reading. If you do not get a zero reading, you may have an open wire.

Ohm the Black, Green and White wires at the pressure transducer to ground. The Black wire should be grounded, the Green and White wires should not.

7.3 Temperature Problem on all Channels:

Temperature is measured using a temperature probe with type K thermocouple (TC) wire. When the TC junction in the tip of the probe is heated, a small signal (approx. 23 micro volts per ‘F) is produced and monitored by the EDC on two extension wires. These extension wires must be made of type K TC material.

When measuring temperature with TC material an ambient reference temperature must be provided. This is done with a reference diode located on pins 10 and 28 of the EDC Middle Connector. The ambient temperature is added to the temperature measured at the TC junction.

Symptom: Inaccurate, jumpy or zero readings on all channels.

1. Problem: The Reference Diode on pins 10 and 28 of the EDC Middle Connector is damaged.

- a) Action: Measure the voltage on the Reference Diode. Pin 28 = 0 volts and pin 10 = approx. 0.5 volts.

2. Problem: One of the temperature input channels is over voltaged. This can happen on a channel that is used to monitor an Annunciator, Flap or Trim function. The max input voltage for any temperature or pressure channel is +5 volts. The VI-221 is used to drop the voltage when measuring signals that switch from ground to bus voltage.

- a) Action: Measure the voltage on each of the temperature channels.

7.4 Temperature Problem with one Function:

Temperature is measured on the aircraft using a temperature probe with type K thermocouple (TC) wire. When the TC junction in the tip of the probe is heated, a small signal (approx. 23 micro volts per °F) is produced and monitored by the EDC on two extension wires. These extension wires must be made of type K TC material.

When measuring temperature with TC material an ambient reference temperature must be provided. This is done with a reference diode located on pins 10 and 28 of the EDC Middle Connector. The ambient temperature is added to the temperature measured at the TC junction.

Symptom: Inaccurate, jumpy or zero reading.

1. Problem: One of the two wires from the Temperature Probe to the EDC is open or shorted to ground.
 - a) Action: Remove the extension cable from the probe. Ohm both wires to ground. Each wire should measure 12.1K ohms to ground.
2. Problem: The temperature probe has a problem.
 - a) Action: Ohm between the two leads of the temperature probe. You should get a short (<10 ohms)
Ohm one lead of the probe to ground. You should get an open (> 100K ohms).

7.5 RPM Problem:

For an engine with magnetos, a pulse is produced on the P-lead for each power stroke of the engine (three pulses per revolution for a six cylinder engine). The pulses can be in the hundreds of volts. An Isolator is connected between the P-lead and the EDC RPM inputs. The EDC monitors both magnetos.

The RPM reading for each RPM channel can be viewed in the "Function Configuration" screen found in the "System Config Screens Menu." This screen can be very helpful when troubleshooting.

Symptom: Inaccurate, jumpy or zero reading.

1. Problem: An Isolator was NOT used between the EDC RPM channel and the P-lead at the back of the Mag Switch. The signal on the P-lead is hundreds of volts and if an isolator is not used in series with this wire, damage to the RPM input on the EDC could occur.
 - a) Action: Check that there is an Isolator(s) in line with the RPM signal wires from the EDC.

If only one RPM channel is working, swap the wires to the EDC RPM channel and see if the problem follows the EDC channel or the wire to the P-lead.
2. Problem: The Isolators in line with the EDC are incorrect.
 - a) Action: If the RPM reading is jumping high, add a "47" or "79" Isolator in series with the existing Isolator. The signal from the P-lead is too strong.

If the RPM signal is from an electronic ignition, there should NOT be any Isolators in the wire to the EDC. The EDC RPM input triggers at 3 volts.

7.6 Fuel Flow Problem:

Fuel Flow is measured using a Flow Transducer. Power (+10 volts on the Red wire) and ground (Black wire) is supplied to the transducer from the EDC. A rotor in the transducer spins and produces pulses (0 to +5 volts) on the White wire. The +5 volts portion of the pulse on the White wire comes from a pull-up resistor in the EDC. The K-factor found in the "Fuel K-Factor" screen calibrates the pulses to produce a flow rate.

Symptom: Inaccurate readings.

1. Problem: The K-factor is incorrect.

- a) Action: Check that the K-factor (found in the "Fuel K-Factor" screen) is correct for the transducer installed in the aircraft (FT-60 red cube = 68,000, FT-90 gold cube = 33,800 and the FT-180 black cube = 22,400).

Symptom: Inaccurate, jumpy or zero reading.

1. Problem: A wire is open, shorted or mis-wired.

- a) Action: Measure the voltage on the transducer wires from the EDC at the Flow Transducer. The Red lead = +10 volts, Black wire = 0 volts, White wire = + 5 volts with the White wire removed from the flow transducer.

Ohm the Black wire to ground. The Black wire must be shorted to ground (< 10 ohms).

Rapidly tap the White transducer wire to ground. A small fuel flow reading should show on the CGR.

1. Problem: The rotor in the Fuel Flow Transducer is blocked.

- a) Action: Remove the Flow Transducer from the aircraft. Lightly blow into the transducer and check for the rotor to spin freely. Check for a Fuel Flow reading on the CGR when the rotor is spinning.

If the rotor in the Flow Transducer does not spin, hold the transducer over white paper and tap at all angles. Debris can lodge in the transducer and block the rotor.

7.7 Amp Problem:

Amps are measured on the aircraft using a Shunt. A Shunt has very low resistance and produces a differential voltage on the two signal wires connected to the Shunt. The differential voltage is proportional to the amperage flowing through the Shunt (50 mV at 50 Amps for the S-50 Shunt). In series with the two signal wires are two fuses to protect the wires from catching fire in case of a short. These fuses should be located a short distance from the Shunt. The wires are then routed to the EDC Amp input.

Symptom: Inaccurate, jumpy or zero reading.

1. Problem: A wire, fuse or fuse connection is open, shorted or mis-wired.

- a) Action: Remove one of the signal wires on the Shunt and connect it to the other signal wire. This will short the two signal wires together. The CGR should read 0.0 amps. A common problem is with the fuses or fuse holders in line with each Amp signal wire from the Shunt to the EDC. The fuses should be located a short distance from the shunt. Inspect the wires, fuses and fuse holders.

7.8 Resistive Fuel Level Problem:

Fuel can be measured in a fuel tank using a Resistive Float Sensor. The sensor must be connected to a RFLM (Resistive Fuel Level Module). This module provides a pull-up resistor to produce a voltage as the float changes resistance with changes in the fuel level. A signal wire connects the float to the RFLM and a wire connects the RFLM to the EDC. The RFLM requires bus voltage to provide the pull-up.

As the float sensor arm moves up, the resistance will change, creating a higher or lower voltage (depending on the float type) on the signal wire. The EDC monitors the signal and produces a digital value (called sensor counts) based on the signal voltage. The sensor counts can be viewed in the "Fuel Tank Calibration" screen. The sensor counts are then converted to a fuel level based on the calibration data in the "Fuel Tank Calibration" screen.

Resistive floats are notoriously inaccurate and inconsistent. Floats move up and down millions of times during their lives. They can move even when the aircraft is parked. The metal-to-metal contact of the wiper to the coil wears and corrodes. The wiper force weakens. The bearing surfaces wear. It's not uncommon to even find new floats that work poorly. The CGR can calibrate out nonlinearity, but inconsistency will always cause reading problems. It will cause you to perform the fuel tank calibration procedure over and over with little or no long-term improvement. Consider using a capacitive probe if at all possible.

Symptom: Inaccurate, jumpy or zero reading.

1. Problem: The RFLM is mis-wired.

- a) Action: Remove the signal wire to the Resistive Float. Check for a very high (or low, depending on the float type) sensor count in the "Function Mapping" screen found in the "Function Configuration" screen. Be sure you are displaying the data for the correct tank.

The voltage on the open signal wire should measure bus voltage.

Short the signal wire to ground. Check the sensor counts go to a low (or high, depending on the float type) reading.

2. Problem: The Resistive Float does not operate properly.

- a) Action: With the signal wire removed, measure the resistance of the float. This should not be done with a full or empty tank but somewhere in-between. Record the resistance reading and the variations. Lift the wing and allow it to return to its original position. Record the resistance reading and the variations. This test can be done at different fuel levels. If the resistance value does not return to its original value, you may have a defective Resistive Float.

Symptom: The sensor counts decrease as you add fuel.

1. Problem: The probe selected in the “Function Configuration” screen may be the wrong probe.

- a) Action: Check the Probe selected in the “Function Configuration” screen. The “RFLM-4 H=F” probe should be used on Resistive Floats where high resistance = full tank readings and the “RFLM-4 L=F” probe should be used on Resistive Floats where low resistance = full tank readings.

7.9 Capacitive Fuel Level Problem:

Fuel can be measured in a fuel tank using a Capacitive Fuel Probe. The Electronics International P-300 Capacitive Fuel Probe connects to an IMC (Interface Module) located near the probe, and to the EDC through three wires. Power (+5 volts) is supplied on the Red wire, ground is supplied on the Black wire and the fuel level signal (a 0 to +5 volt square wave) is supplied (by the P-300C) on the White wire.

As the fuel level in the tank increases, the capacitance of the probe increases. The IMC Module converts the capacitance to a frequency. The higher the fuel level, the lower the frequency of the square wave on the White wire.

The EDC monitors the signal and produces a digital value (called sensor counts) based on the signal frequency. The sensor counts can be viewed in the “Function Mapping” screen. The sensor counts are then converted to a fuel level based on the calibration data in the “Function Mapping” screen.

Symptom: Inaccurate, jumpy or zero reading.

1. Problem: The IMC is mis-wired.

- a) Action: Measure the voltage on the three wires at the IMC Module (Red wire = +5 volts, Black wire = ground, White wire = +2.5 volts).

Remove the Red wire from the IMC module and check the sensor counts on the “Function Mapping” screen to increase. Be sure you are displaying the data for the correct tank.

Touch the outside of the wires between the IMC Module and the probe and check that the sensor counts increase.

2. Problem: The P-300 Fuel Probe is shorted or there is water or contamination in the tank.

a) Action: Remove the wire from the IMC Module to the center terminal of the P-300 probe. Ohm the center terminal of the P-300 probe to ground. Check for > 10 M Ohms. Remove the probe from the tank to resolve any issues.

7.10 Voltage Problem:

Bus voltage is measured on EDC pin 35 of the top connector.

Symptom: Inaccurate, jumpy or zero reading.

1. Problem: Pin 35 on the EDC top connector is mis-wired.

a) Action: Measure the voltage on pin 35 (look for bus voltage).

Technical Data

Specifications, Functions and Features

Specifications / Features

0226131

Rev. A: 07/25/2018

Models: CGR-30P, CGR-30C, EDC-33P and EDC-33T-XX

CGR-30P and CGR-30C

Weight: 1.1 Lbs.

Environmental: Designed and Tested to TSO (DO-160G)

Software: Designed and Documented to TSO (DO-178B, Level C)

Minimum Performance Standards: TSO-C43c, TSO-C44c, TSO-C45b, TSO-C47a, TSO-C48a, TSO-49b and TSO-C55a.

Power Requirements: 7.5 to 30 Volts, 0.1 amps @ 24V (Typ), 0.2 amps @ 12 Volts (Typ).

USB Port: For USB Memory Stick use only.

Display: Active Matrix TFT, 262,144 colors, Sunlight readable

Backlight: External control line, programmable levels.

CGR-30P Functions:

- **Display of Primary Gauges with Red and/or Yellow Ranges:** Five on the Main Screen + EGT and CHT. One on the Secondary Screen.
- **Display of Primary and Non-Primary Gauges without Red and/or Yellow Ranges:** Five on the Main Screen + EGT and CHT. Six on the Secondary Screen.
- **Derived Function from Fuel Flow:** Fuel Remaining, Fuel Used Since Fill-up, Fuel Used for the Flight and Time to Empty. Fuel Remaining, Fuel Used Since Fill-up and Fuel Used for the Flight.
- **Derived Functions from GPS and Fuel Flow (Estimated):** Time to Destination, Time Reserve, Distance to Destination, Distance to Empty, Distance Reserve, Fuel to Destination, Fuel Reserve and Economy.
- **Derived Functions from Internal Timer:** Date, Local Time and Zulu Time.
- **Derived Functions from RPM:** Engine Time and Tach Time, Horsepower (also required M.P.)

CGR-30C Functions:

- **Display of Primary Gauges with Red and/or Yellow Ranges:** Ten on the Main Screen + EGT and CHT. Six on the Secondary Screen. Any unused primary gauge locations may be used to display non-primary gauges.
- **Derived Functions from Internal Timer:** Date, Local Time and Zulu Time.
- **Derived Functions from RPM:** Engine Time and Tach Time, Horsepower (also required M.P.)

Error Messages:

“**COM**” - If communication is lost with the EDC, after 2 seconds all functions requiring signals from the EDC will display “COM” for its value.

“**A2D**” - If the EDC sends an error message for a specific channel, the function associated with that channel (on the MVP) will display “**A-D**” for the value.

“**OVR**” - If a channel on the EDC is over ranged (>2.5 volts differential), an “OVR” will be displayed for that function.

“**REF**” - If the reference for any function has a problem or a derived value used to calculate the function has a problem, the display for the function will show “REF.”

“**FPR**” - If a capacitance fuel probe is unplugged, or water touches the center electrode, the digital value for the fuel level will displayed “FPR.”

EDC-33P and EDC-33T-XX (S Version)

Weight: 1.0 Lb

Environmental: Designed and Tested to TSO (DO-160E)

Software: Designed and Documented to TSO (DO-178B, Level C)

Power Requirements: 7.5 to 50 Volts, 0.1 amps (Typ).

Accuracy all Functions: $\leq 1\%$ (Unless otherwise noted)

Input Configuration:

EDC-33P: 1-Volt Channel, 1-Amp Channel, 1-Fuel Flow Channel, 6-Pressure Channels, 17-Temp Channels, 4-Resistive Fuel Level Channels, 4-Capacitive Fuel Level Channels and 2-RPM Channels.

EDC-33T-XX: 1-Volt Channel, 1-Amp Channel, 1-Fuel Flow Channel, 9-Pressure Channels, 13-Temp Channels, 4-Resistive Fuel Level Channels or 4-Capacitive Fuel Level Channels and 2-RPM Channels.

Note: Temp, Fuel Level and Pressure channels can be used to monitor other functions or annunciators.

Volts:

Measured on pin 35 of the EDC Top Connector.

Input Resistance: 83.8K Ohms.

Range: 0 to 40 volts.

Sensitivity: 6400 counts per volt.

Note: A VI-221 or FM-VA-MVP-xx may be used to measure Voltage on any temperature channel.

Amps:

Common Mode Input Resistance: > 10 M Ohms
Diff. Input Resistance: 10K Ohms
Differential Input: +2.5V to -.2V
Common Mode: +/- 90 Volt to ground
Sensitivity: 9.537uV per count.

Note: An FM-VA-MVP-xx module may be used to measure Voltage and Amps on any two temp channels.

Fuel Flow:

Input Configuration: 5.11K Ohm pull-up to +5 Volts
Input Trigger: 2.5 Volt with over voltage protection.
Operating Range: 0 to 15 KHz.
Sensitivity: One count per pulse measure over a 0.356 second period.

Notes:

- * **+10 Volts are provided from the EDC to energize the flow transducer.**
- * **An FFDM-1-MVP module may be used to accommodate fuel return from a pressure carburetor.**
- * **A FM-Flow-P module may be used to measure flow from a pulsed injector.**

RPM, Piston (EDC-33P): Two RPM channels are available. May be configured for digital or mag pickup. Also, may be set up to operate from one or two inputs. Selectable jumpers and different EDC models accommodate 2, 4, 6, 8, etc. cylinder engines. Inputs are over voltage protected. Mag Out feature provided.

Input Trigger: +3V / -1V
Input Resistance: 2.06K with 1 volt pull up.
Max RPM (EDC-33P-4/6): 4500, see Appendix for information on high RPM EDC units.
Sensitivity (EDC-33P-4/6): 20 counts per RPM

Notes: A 79K isolation resistor (supplied in the kit) must be put in series with the input when measuring signal from mags.

Max RPM: 6140 Hz.
Sensitivity: 16.1 sensor counts per Hz.
Accuracy: <= 0.5%

RPM, Turboprop:

Two RPM channels are available to measure N1, N2, Ng, Nh, Hp, Hl or other turboprop RPM functions. The "Engine Data, Ports, Timers, etc. Setup" screen provides data to calibrate these RPM values for a given tach generator output.

EDC-33T (Both RPM Channels):

Input Trigger: +.39V / 0V (Hysteresis)
Input Resistance: 20K ohms
Max RPM: 123 Hz.
Accuracy: $\leq .5\%$

EDC-33T-H1:

Ch 1, Rotor:

Input Trigger: +.39V / 0V (Hysteresis)
Input Resistance: 20K ohms
Max RPM: 266 Hz.
Sensitivity: 372 sensor counts per Hz.
Accuracy: $\leq .5\%$

Ch 2, N1:

Input Trigger: +.11V / 0V (Hysteresis)
Input Resistance: 20K ohms
Max RPM: 6140 Hz.
Sensitivity: 16.1 sensor counts per Hz.
Accuracy: $\leq .5\%$

EDC-33T-W (Both RPM Channels):

Input Trigger: +.054V / 0V (Hysteresis)
Input Resistance: $>1\text{M ohm}$
Max RPM: 11.0 KHz.
Sensitivity: 8.963 sensor counts per Hz.
Accuracy: $\leq .5\%$

Pressure:

Input: 0 to 2.5 Volts Differential
Input Impedance: $> 20\text{M Ohms}$
Common Mode Range on the Input: + 4 Volts to -.2 Volts (from ground).
+5 Volt and Ground provided to energize the pressure transducer.
Sensitivity: Ratiometric to the EDC +5 Volt supply ($9.537\mu\text{V} \times (5/(\text{voltage of the EDC +5V supply}))$)

Notes: Many pressure transducers are available to monitor many different functions. See an E.I. price sheet for a list of pressure transducers available.

Temperature:

Input Range: 0 to 2.5 Volts Differential

Input Impedance: 12.1K Ohms on each input to ground

Sensitivity: 9.537uV per count.

Notes:

* Any Temp Channel may be used to measure any thermocouple probe or any device outputting a voltage. In this way many different types of function may be monitored through a temperature channel. See an E.I. price sheet for a list of modules available.

* A Reference junction is provided to accommodate TC probes. Temp channel 8 is closest to the "Ref Diode" and is best used for measuring OAT.

Resistive Fuel Level: The resistive and capacitive inputs share channels. Only one input type should be used per channel.

Input Range: 0 to 18 Volts single-ended input.

Input Impedance: 14.4K Ohms.

Sensitivity: .07169mV per count when set for non ratiometric measurement.

Notes:

* The Resistive Fuel Level inputs may be used to monitor other functions or annunciators.

* When monitoring a resistive probe a RFLM-4-12 or -24 module will be required (see E.I. price sheets). Also, measurements are made ratiometric to the bus voltage.

Capacitive Fuel Level: The resistive and capacitive inputs share channels. Only one input type should be used per channel.

Input Trigger Level: 2.1 Volts

Frequency Range: 0 to 15KHz.

Input Impedance: 33.2K Ohms

Sensitivity: 14 counts per Hz..

Notes: The Capacitive Fuel Level inputs may be used to monitor other functions.

Appendix

A1.0 LASAR Ignition RPM Filter

A2.0 EDC-33P-8 for 7, 8, 9-Cylinder Engines and High RPM Engines

A3.0 Connecting an EDC RPM Channel to a Lightspeed Plasma II or III Ignition

A4.0 CGR-30P Twin Engine Installation Instructions

STC and AML

Appendix - 1

LASAR Ignition RPM Filter

Rev: New 5/2/07

The LPF-1 is a low-pass filter designed to remove the high frequency spikes on the LASAR Ignition RPM output. Without this filter the RPM readings on the CGR unit may display jumpy readings at various engine RPMs. The LPF-1 should be installed between the LASAR RPM output and the EDC RPM input.

LPF-1 Used with the CGR System:

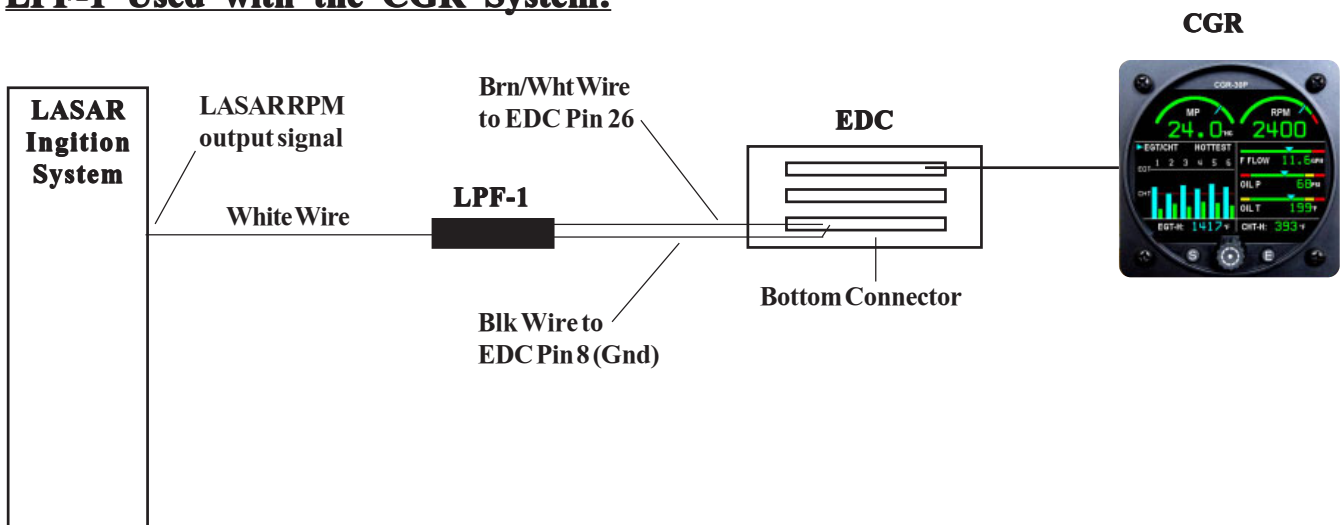

Appendix - 2

EDC-33P-8

for

7, 8, 9-Cylinder Engines and High RPM Engines

The EDC-33P-4/6 is EI's standard unit designed to work with 4 and 6-cylinder aircraft engines. The EDC-33P-8 unit is designed to work with 7, 8, and 9-cylinder aircraft engines. Also, the EDC-33P-8 can interface with 4, 6 and 8-cylinder high RPM engines (>4500 RPM). The RPM inputs are the only difference between the EDC units.

The Top and Middle “EDC Wiring Work Sheets” are the same for the EDC-33P-4/6 and -8 units. Only the Bottom Connector is different for the -8 unit. The “EDC Wiring Work Sheet” for the EDC-33P-8 Bottom Connector is attached. The specifications for the EDC-33P-8 RPM inputs are listed below. For any CGR probe not listed, you can manually set up the CGR calibration.

Engine	CGR Probe	Pin 28 Bottom Connector	Max RPM
4-Cyl	RPM 4H/8H	Open	9,600
6-Cyl		Open	6,400
7-Cyl	RPM 7Cyl	Open	5,200
8-Cyl	RPM 8Cyl	Open	4,800
9-Cyl	RPM 9Cyl	Open	4,270
6-Cyl	RPM 6H	Short to Gnd	12,600
8-Cyl	RPM 4H/8H	Short to Gnd	9,450
9-Cyl		Short to Gnd	8,400
10-Cyl		Short to Gnd	7,600
12-Cyl		Short to Gnd	6,300

Appendix - 3

Connecting an EDC RPM Channel to a Lightspeed Plasma II or III Ignition

Rev. A

All Plasma II and Plasma III version B units have a +10 Volt pulse output and can be connected directly to the RPM input on the EDC. All Plasma III version A units have an open collector output and require a pull-up resistor to produce a pulse required by the EDC. Lightspeed recommends returning the unit to their factory to have the pull-up resistor installed internally.

1. Connect the Lightspeed "Elec. Tach" signal to the EDC RPM Channel:

Connect Pin 6 (SIGNAL TO ELEC. TACH) of the Lightspeed INPUT connector to the EDC RPM input channel. An isolator is not required in this line. Use shielded wire as described in Lightspeed's documentation. **Tie wrap all wires so they do not obstruct the freedom of travel of any controls.**

2. Tie the shield of the Lightspeed tach out signal to ground:

Connect pin 13 (SHIELD) of the Plasma INPUT connector to ground (pin 14). Do not connect this shield to ground on the EDC.

NOTE: Check your Lightspeed documentation, as pin numbers and connection names may change.

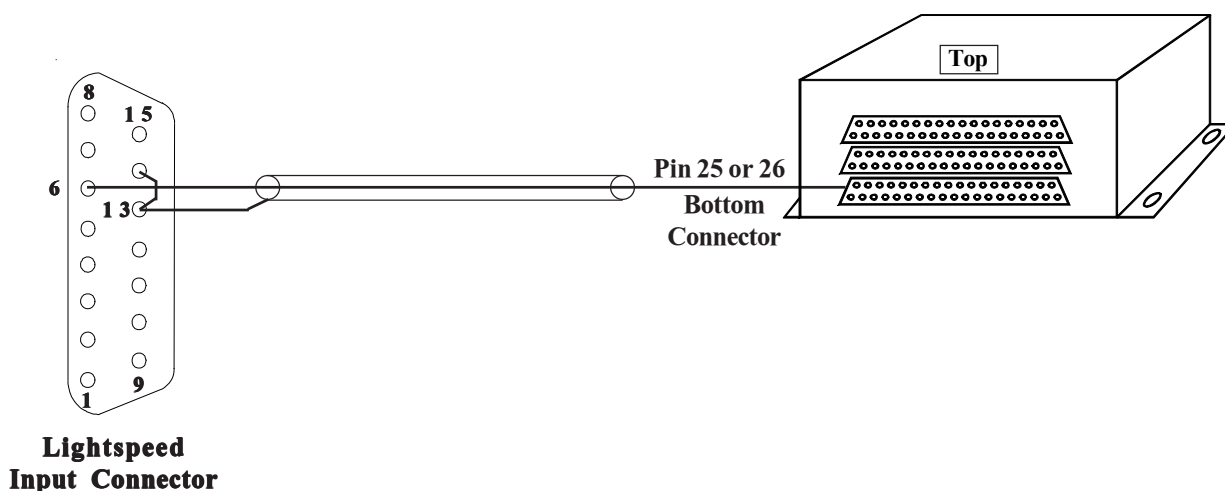

Appendix - 4

CGR-30P

Twin Engine Installation Instructions

1.0 Installation Overview:

The twin engine system consists of two CGR-30Ps, one for the right engine and one for the left engine. The diagram below also shows the CGR-30C. The CGR-30C is not required to be installed, but considering the number of functions to be monitored in a twin engine system and the limited number of functions each CGR-30P is capable of displaying, the CGR-30C will most likely be ordered with each twin engine package.

Two EDCs will also be provided. The EDCs convert the analog signals from the probes and transducers to a single wire digital data string sent to the CGR-30P head. This keeps the wire count through the wing root to a minimum. One EDC will be mounted just behind the firewall on both the left and right engines. This allows the significant number of probe wires and cables to be as short as possible. The engine EDCs will monitor such functions as EGTs, CHTs, RPM, Fuel Flow, Oil P, Oil T, etc. If the CGR-30Ps are displaying their maximum number of functions, any additional functions can be displayed on the CGR-30C.

The cabin provides the pressure lines for manifold pressure and vacuum. Mount the MP and Vac pressure transducers in the cabin and run the transducer signal wires to the appropriate EDCs. This allows some of the more sensitive transducers to be mounted in the cabin environment. Also, in some cases other function can more easily be monitored from the cabin.

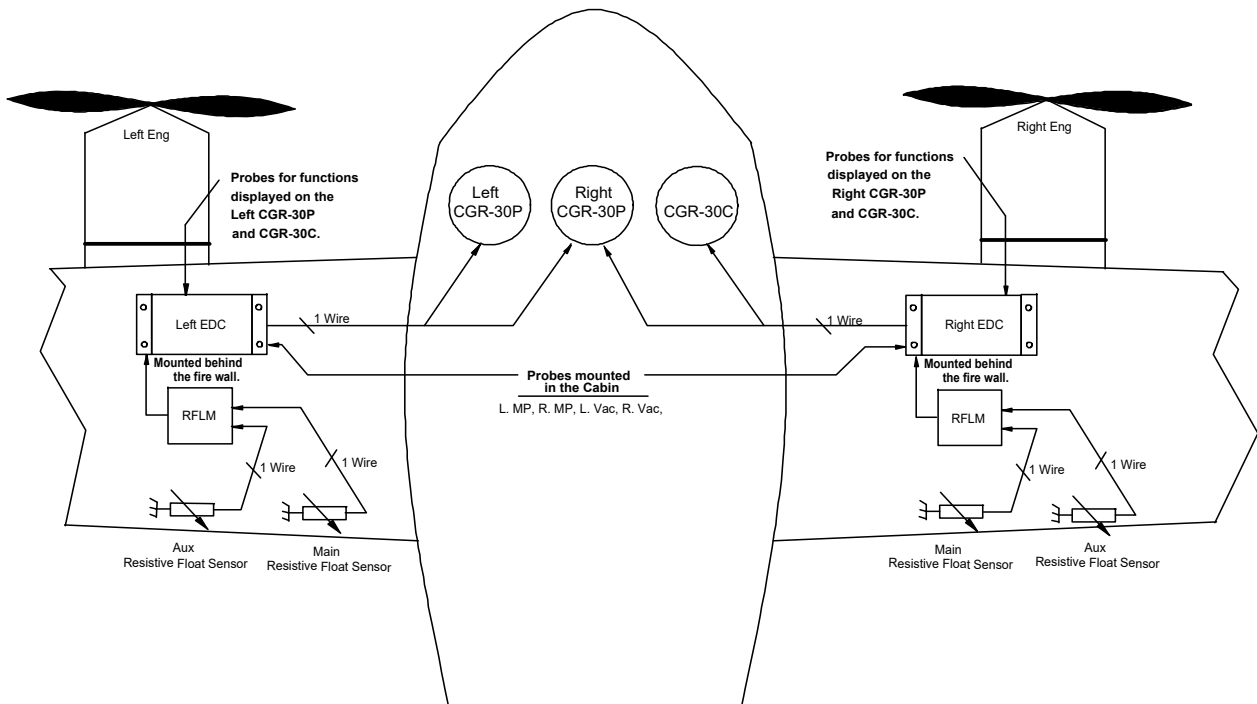

1.1 Installation Instructions:

The installer should start the installation by reviewing the EDC Wiring Work Sheets. There are three sets of worksheets, one set for each EDC and one set for the CGR-30. Each EDC set will have three sheets, one for each of the 37-pin D-Sub connectors on the EDC (Top, Middle and Bottom). The work sheets are packaged with each of the three EDC wire harnesses. The work sheets provide a list of the probes and transducers included in the kit. Also, it provides the hookup data.

Install the system by performing all the steps at the beginning of this manual. Additional information for twin engine installations is provided below:

- A. The Left and Right EDCs will be installed on the back side of the engine's firewall or in the wing. Note: The EDCs should NOT be installed on the hot side of the engine compartment.
- B. Install the two CGR-30P displays in the instrument panel on the same horizontal or vertical plane and within 2 inches of each other.
- C. Install the Caution and Warning Mounting Plates as follows:
 - 1) If the two CGR-30Ps are mounted side-by-side, install the Mounting Plates horizontally, side-by-side with the left Plate annunciating the left instrument or mount the Plates vertically, top-to-bottom with the top Plate annunciating the left instrument.
 - 2) If the two CGR-30Ps are mounted top-to-bottom, install the Mounting Plates vertically, top-to-bottom with the top Plate annunciating the top instrument or mount the Plates horizontally, side-by-side with the left Plate annunciating the top instrument.
- D. The power lead for the Left CGR-30P, Left EDC and Left Caution and Warning Lights should be on one 5 to 10-amp breaker, the power lead for the Right CGR-30P, Right EDC and Right Caution and Warning Lights should be on another 5 to 10-amp breaker and the power lead for the CGR-30C, should be on yet another 5 to 10-amp breaker. These breakers should be on the Master Bus.



Providing **Superior** Products
and Unparalleled Customer Service Since 1979



 Learn more about Electronics International and its products at iFlyEi.com